



STL
ALUMÍNIO

LINHA

AR CONDICIONADO

PERFIL EXTRUDADO DE ALUMÍNIO

CATÁLOGO Ver 1.0 | DEZ 24

PERFIL	MERCADO	KG/M	PÁG.
STL-0058	—	0,061	03
STL-0111	—	0,091	04
STL-0112	—	0,261	07
STL-0129	—	0,215	08
STL-0130	—	0,279	08
STL-0430	—	0,185	08
STL-0431	—	0,348	08
STL-0458	—	0,118	05
STL-0826	—	0,245	06
STL-0827	—	0,221	09
STL-0828	—	0,354	06
STL-0845	—	0,127	05
STL-0849	—	0,169	04
STL-0889	—	0,283	09
STL-0890	—	0,090	03
STL-0891	—	0,201	07
STL-0892	—	0,296	05
STL-0940	—	0,178	07
STL-0941	—	0,173	09
STL-1117	—	0,310	06
STL-1118	—	0,352	06
STL-1119	—	0,169	04
STL-1172	—	0,070	03
STL-1486	—	0,770	10
STL-1707	—	0,107	05
STL-1708	—	0,213	05

STL-0058

Merc. -----

Peso 0,061 kg/m

Descr. -----

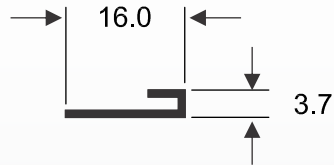

STL-0890

Merc. -----

Peso 0,090 kg/m

Descr. -----

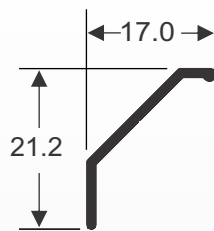

STL-1172

Merc. -----

Peso 0,070 kg/m

Descr. -----

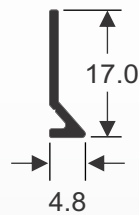

STL-0111

Merc. -----

Peso 0,091 kg/m

Descr. -----

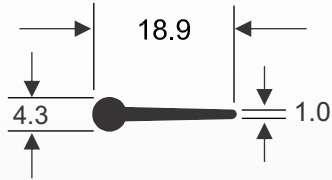

STL-1119

Merc. -----

Peso 0,169 kg/m

Descr. -----

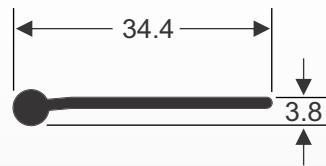

STL-0849

Merc. -----

Peso 0,169 kg/m

Descr. -----

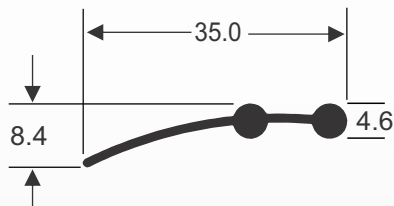

STL-1707

Merc. -----

Peso 0,107 kg/m

Descr. -----

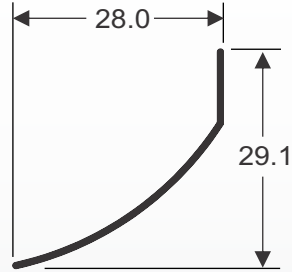

STL-0458

Merc. -----

Peso 0,118 kg/m

Descr. -----

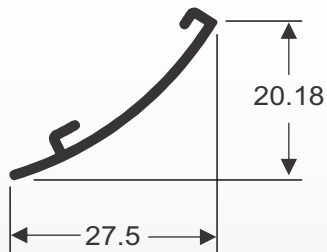

STL-0845

Merc. -----

Peso 0,127 kg/m

Descr. -----

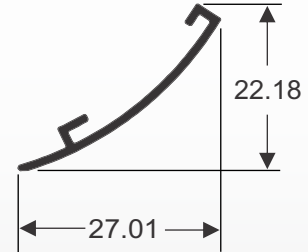

STL-1708

Merc. -----

Peso 0,213 kg/m

Descr. -----

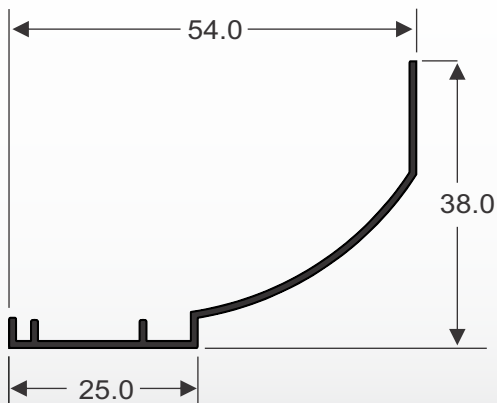

STL-0892

Merc. -----

Peso 0,296 kg/m

Descr. -----

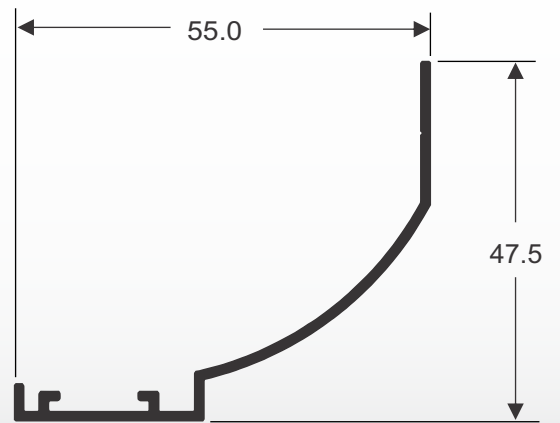

STL-1117

Merc. -----

Peso 0,310 kg/m

Descr. -----

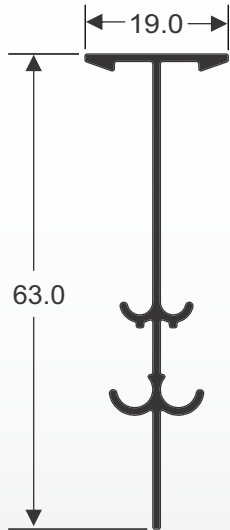

STL-1118

Merc. -----

Peso 0,352 kg/m

Descr. -----

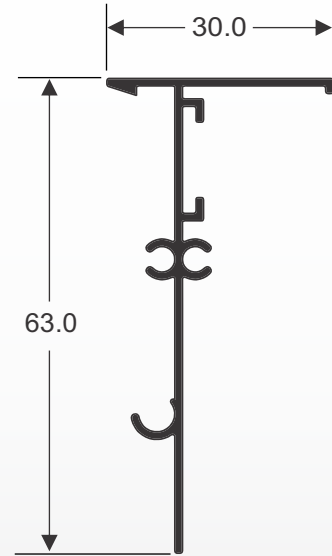

STL-0826

Merc. -----

Peso 0,245 kg/m

Descr. -----

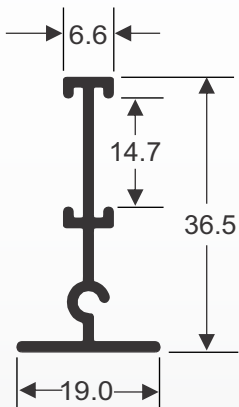

STL-0828

Merc. -----

Peso 0,354 kg/m

Descr. -----

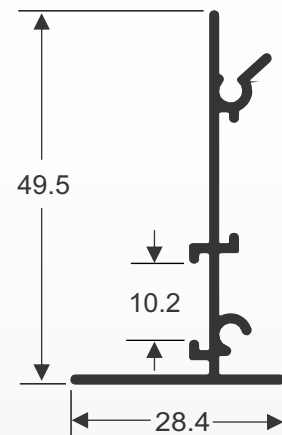

STL-0940

Merc. -----

Peso 0,178 kg/m

Descr. -----

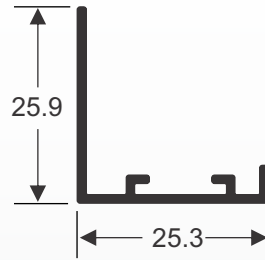

STL-0112

Merc. -----

Peso 0,261 kg/m

Descr. -----

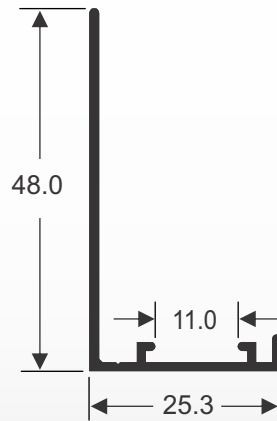

STL-0891

Merc. -----

Peso 0,201 kg/m

Descr. -----

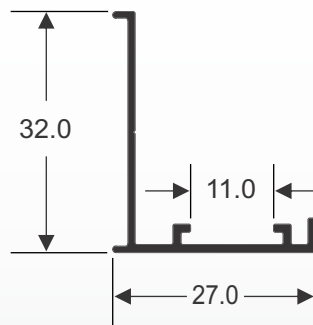

STL-0430

Merc. -----

Peso 0,185 kg/m

Descr. -----

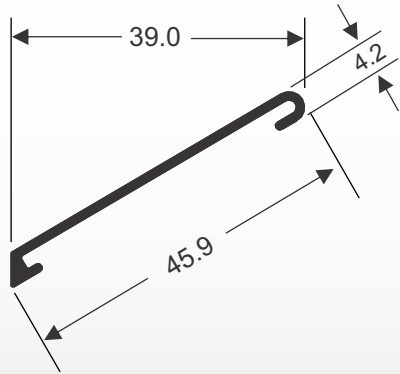

STL-0129

Merc. -----

Peso 0,215 kg/m

Descr. -----

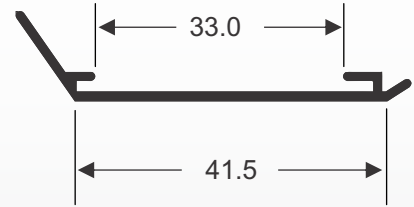

STL-0130

Merc. -----

Peso 0,279 kg/m

Descr. -----

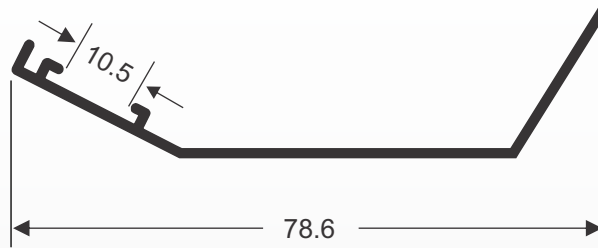

STL-0431

Merc. -----

Peso 0,348 kg/m

Descr. -----

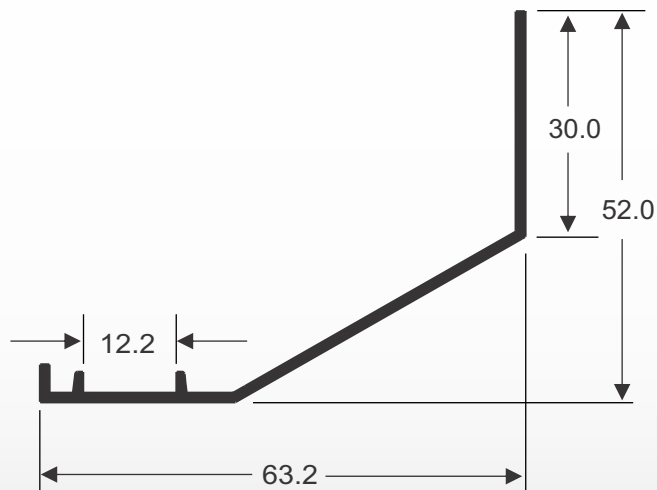

STL-0941

Merc.-----

Peso 0,173 kg/m

Descr.-----

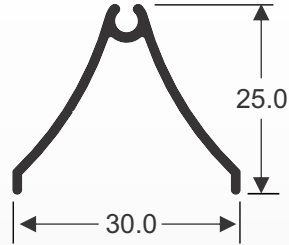

STL-0827

Merc.-----

Peso 0,221 kg/m

Descr.-----

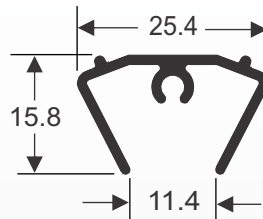

STL-0889

Merc.-----

Peso 0,283 kg/m

Descr.-----

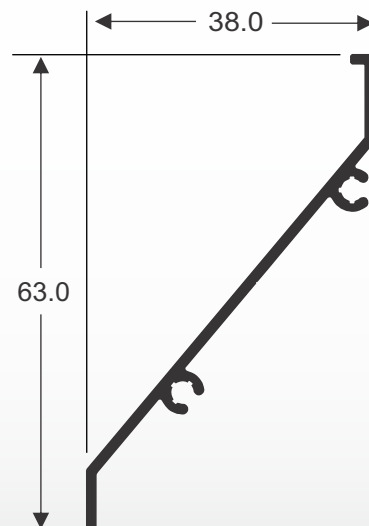

STL-1486

Merc. -----

Peso 0,770 kg/m

Descr. -----

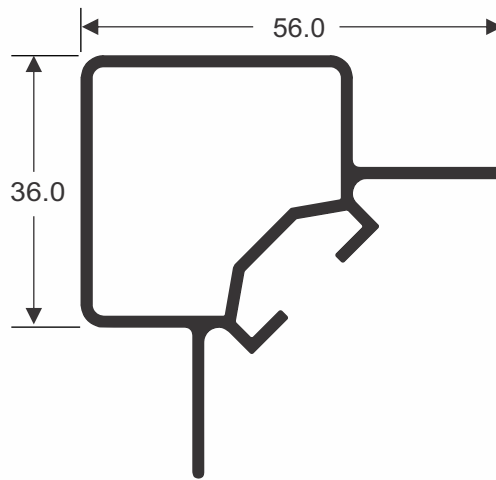



STL
ALUMÍNIO



stlaluminio.com.br



Av. Industrial, 1500 - Distrito Industrial - CEP 08586-150
Itaquaquecetuba - SP - Tel.: 55+ 11 4233-9012