



STL
ALUMÍNIO

LINHA

**BICICLETA
MOTOS**

PERFIL EXTRUDADO DE ALUMÍNIO

CATÁLOGO Ver 1.0 | DEZ 24

PERFIL	MERCADO	KG/M	PÁG.
LEX-0039	—	2,230	20
STL-0035	—	0,193	03
STL-0036	—	0,193	04
STL-0093	—	0,345	06
STL-0124	—	1,063	16
STL-0158	—	0,317	07
STL-0170	—	0,225	03
STL-0171	—	0,482	17
STL-0172	—	1,291	10
STL-0173	—	1,102	09
STL-0190	—	0,232	08
STL-0192	—	0,288	06
STL-0193	—	1,421	11
STL-0200	—	0,783	13
STL-0205	—	0,491	21
STL-0209	—	0,285	19
STL-0210	—	0,273	04
STL-0218	—	0,268	03
STL-0220	—	1,473	10
STL-0225	—	0,969	09
STL-0245	—	0,262	06
STL-0252	—	0,618	13
STL-0253	—	0,120	17
STL-0256	—	0,604	20
STL-0257	—	0,172	05
STL-0258	—	0,204	08
STL-0259	—	0,217	04
STL-0269	—	0,278	05
STL-0326	—	0,278	21
STL-0350	—	0,243	07
STL-0351	—	0,388	13
STL-0353	—	1,005	18
STL-0357	—	0,443	16
STL-0616	—	0,829	18
STL-0678	—	0,147	19
STL-0717	—	0,662	21
STL-0730	—	0,367	16
STL-1026	—	0,561	16
STL-1342	—	0,863	13
STL-1354	—	0,524	14
STL-1373	—	0,703	15
STL-1462	—	0,759	18
STL-1480	—	0,603	17
STL-1491	—	0,226	05
STL-1627	—	0,624	23
STL-1630	—	1,287	21
STL-1646	—	1,594	22
STL-1735	—	0,507	22

PERFIL	MERCADO	KG/M	PÁG.
STL-1752	—	1,746	22
STL-1753	—	0,328	12
STL-1754	—	0,532	14
STL-1755	—	0,694	12
STL-1756	—	2,077	22
STL-1760	—	0,322	07
STL-1765	—	2,894	11
STL-1826	—	0,656	15
STL-1827	—	0,523	14
STL-1828	—	0,531	14
STL-1831	—	0,584	14
STL-1849	—	0,281	23
STL-1927	—	0,519	23
STL-1928	—	0,748	23

STL-0218

Merc. -----

Peso 0,268 kg/m

Descr. -----

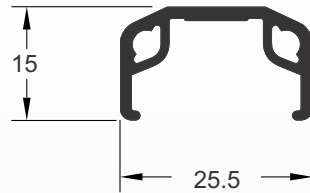

STL-0035

Merc. -----

Peso 0,193 kg/m

Descr. -----

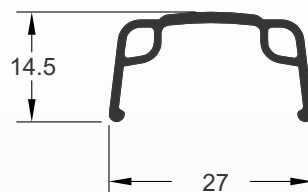

STL-0170

Merc. -----

Peso 0,225 kg/m

Descr. -----

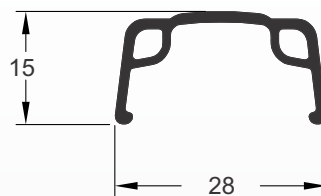

STL-0036

Merc. -----

Peso 0,193 kg/m

Descr. -----

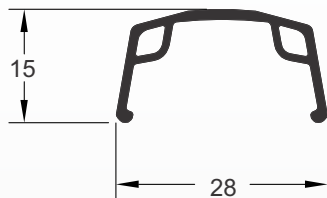

STL-0259

Merc. -----

Peso 0,217 kg/m

Descr. -----

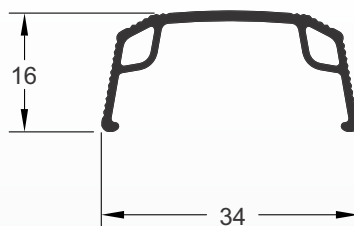

STL-0210

Merc. -----

Peso 0,273 kg/m

Descr. -----

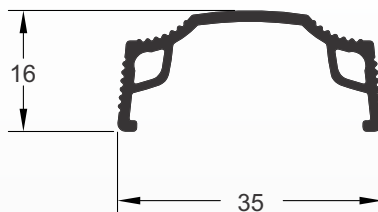

STL-0257

Merc. -----

Peso 0,172 kg/m

Descr. -----

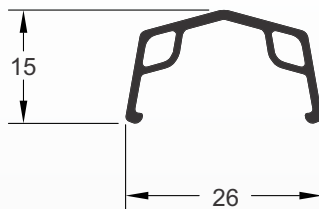

STL-1491

Merc. -----

Peso 0,226 kg/m

Descr. -----

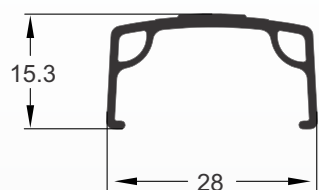

STL-0269

Merc. -----

Peso 0,278 kg/m

Descr. -----

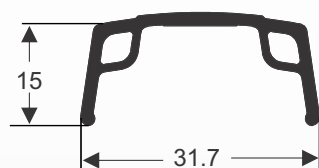

STL-0093

Merc. -----

Peso 0,345 kg/m

Descr. -----

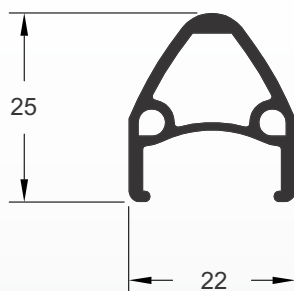

STL-0245

Merc. -----

Peso 0,262 kg/m

Descr. -----

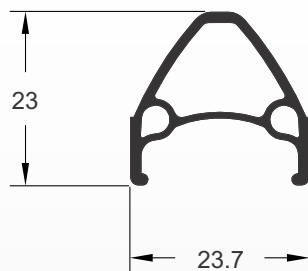

STL-0192

Merc. -----

Peso 0,288 kg/m

Descr. -----

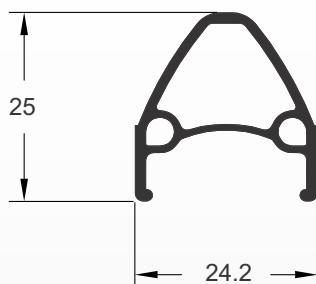

STL-0350

Merc. -----

Peso 0,243 kg/m

Descr. -----

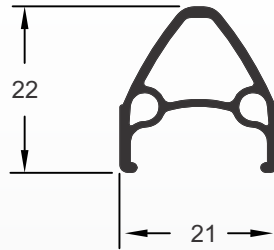

STL-0158

Merc. -----

Peso 0,317 kg/m

Descr. -----

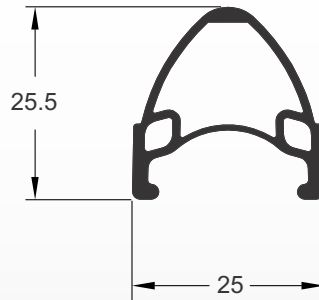

STL-1760

Merc. -----

Peso 0,322 kg/m

Descr. -----

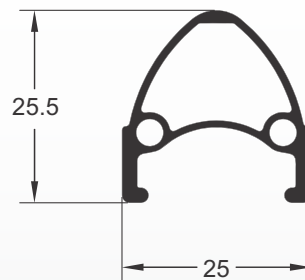

STL-0258

Merc.-----

Peso 0,204 kg/m

Descr.-----

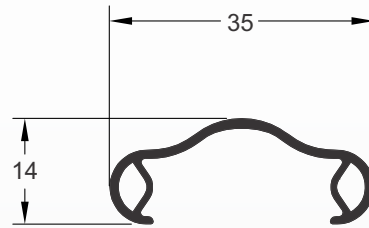

STL-0190

Merc.-----

Peso 0,232 kg/m

Descr.-----

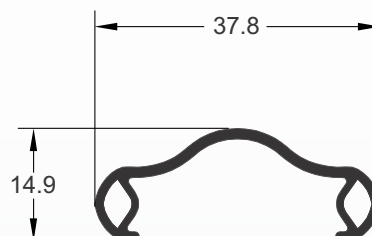

STL-0225

Merc. -----

Peso 0,969 kg/m

Descr. -----

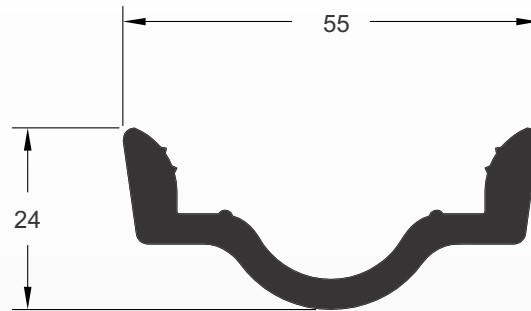

STL-0173

Merc. -----

Peso 1,102 kg/m

Descr. -----

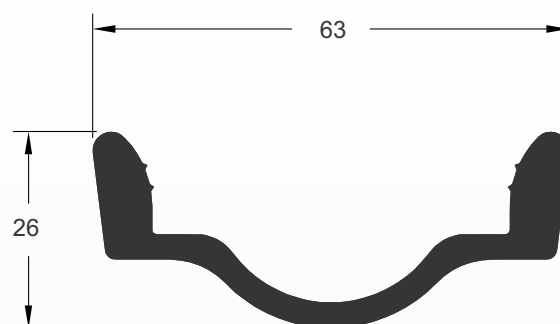

STL-0172

Merc.-----

Peso 1,291 kg/m

Descr.-----

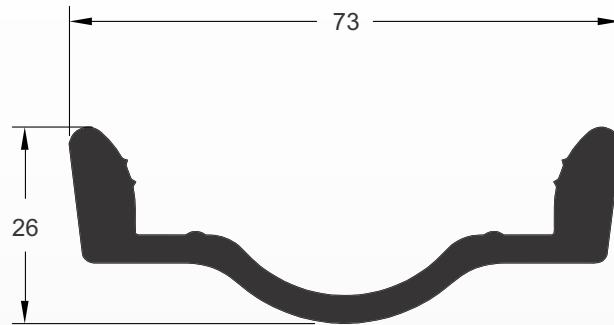

STL-0220

Merc.-----

Peso 1,473 kg/m

Descr.-----

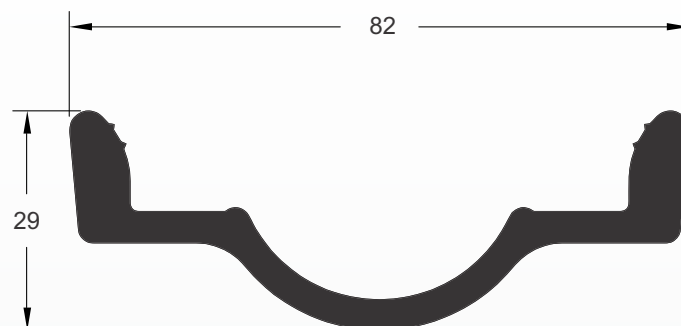

STL-0193

Merc. -----

Peso 1,421 kg/m

Descr. -----

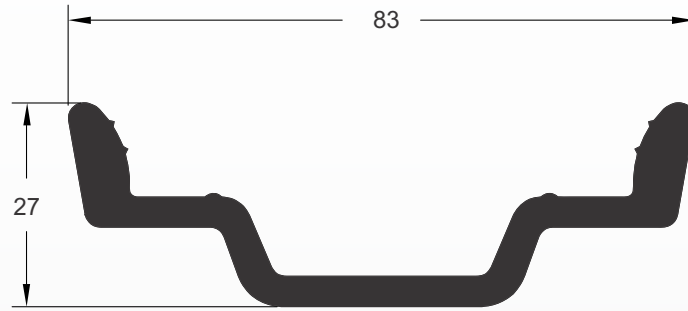

STL-1765

Merc. -----

Peso 2,894 kg/m

Descr. -----

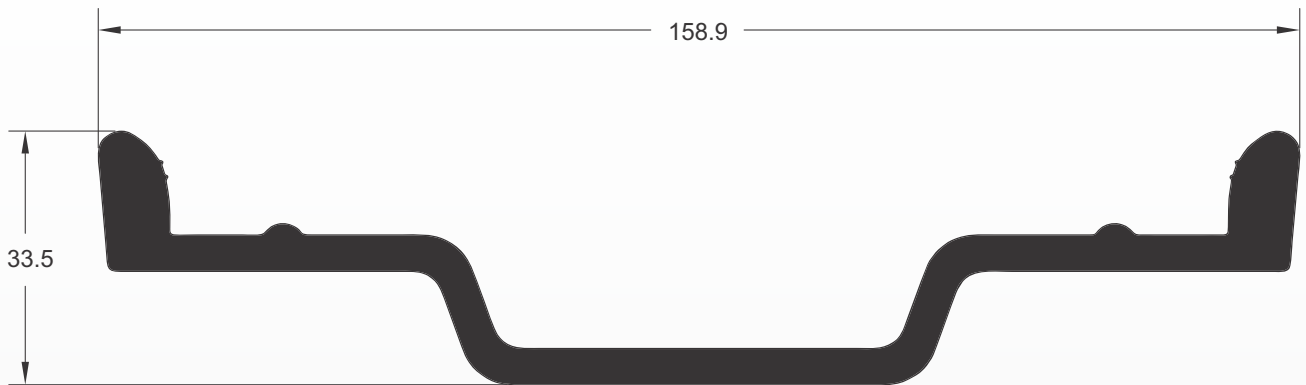

STL-1753

Merc. -----

Peso 0,328 kg/m

Descr. -----

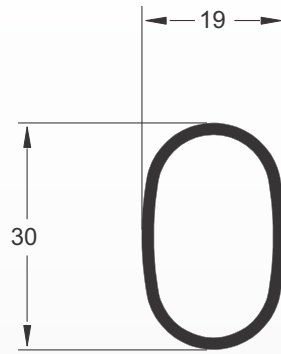

STL-1755

Merc. -----

Peso 0,694 kg/m

Descr. -----

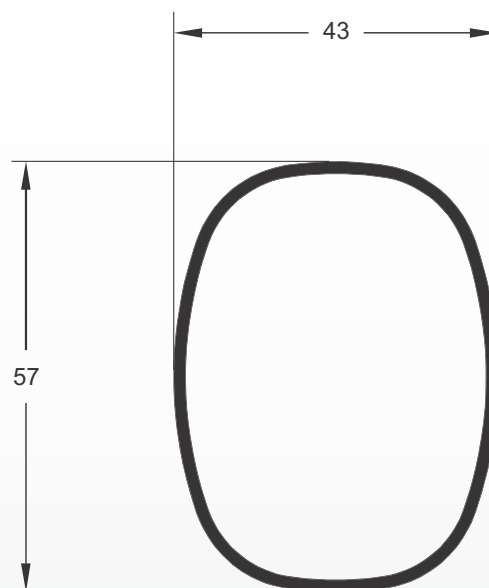

STL-0351

Merc. -----

Peso 0,388 kg/m

Descr. -----

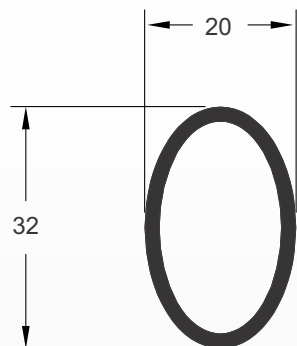

STL-0252

Merc. -----

Peso 0,618 kg/m

Descr. -----

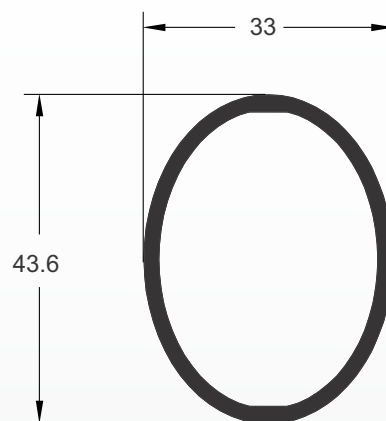

STL-0200

Merc. -----

Peso 0,783 kg/m

Descr. -----

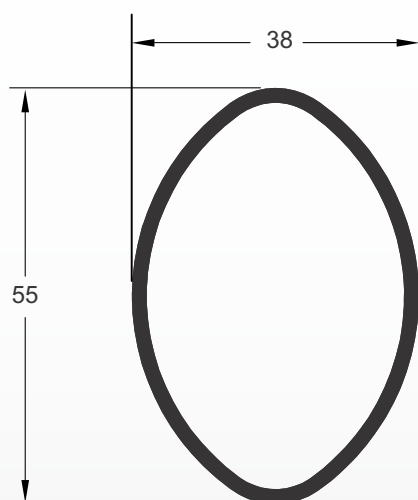

STL-1342

Merc. -----

Peso 0,863 kg/m

Descr. -----

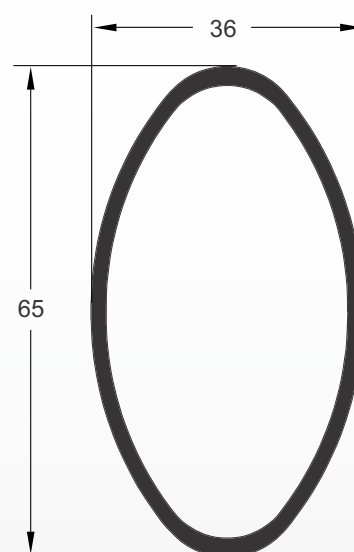

STL-1754

Merc. -----

Peso 0,532 kg/m

Descr. -----

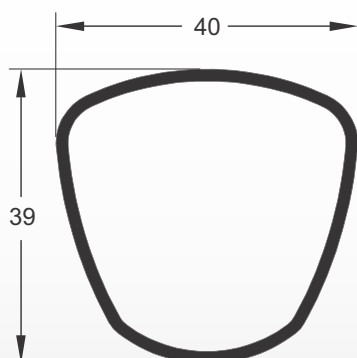

STL-1827

Merc. -----

Peso 0,523 kg/m

Descr. -----

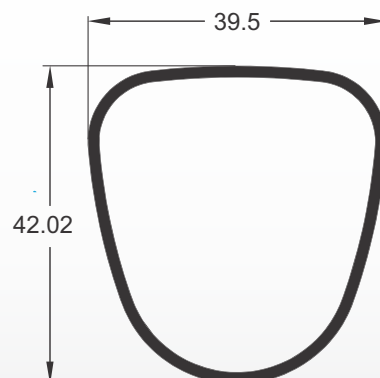

STL-1828

Merc. -----

Peso 0,531 kg/m

Descr. -----

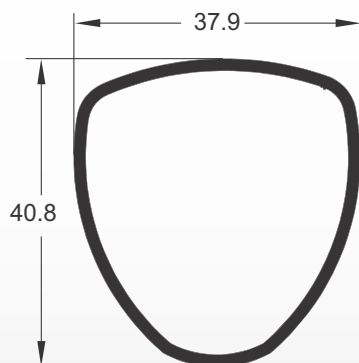

STL-1831

Merc. -----

Peso 0,584 kg/m

Descr. -----

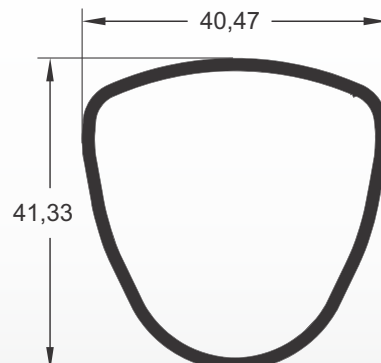

STL-1354

Merc. -----

Peso 0,524 kg/m

Descr. -----

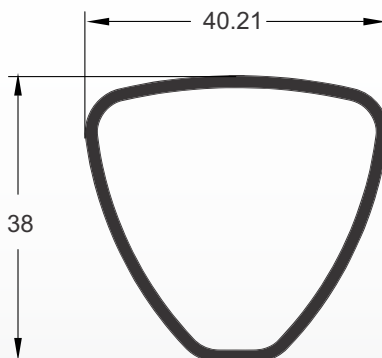

STL-1373

Merc. -----

Peso 0,703 kg/m

Descr. -----

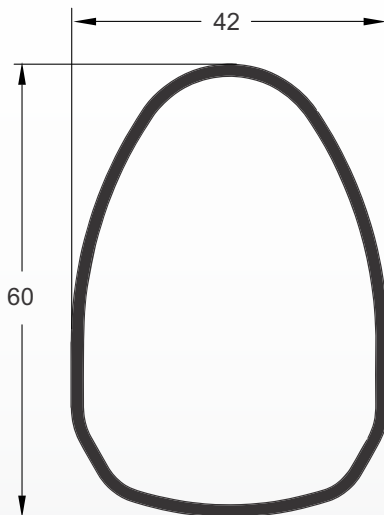

STL-1826

Merc. -----

Peso 0,656 kg/m

Descr. -----

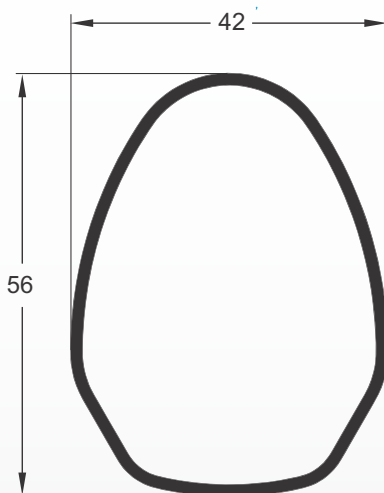

STL-0730

Merc. -----

Peso 0,367 kg/m

Descr. -----



STL-1026

Merc. -----

Peso 0,561 kg/m

Descr. -----



STL-0124

Merc. -----

Peso 1,063 kg/m

Descr. -----

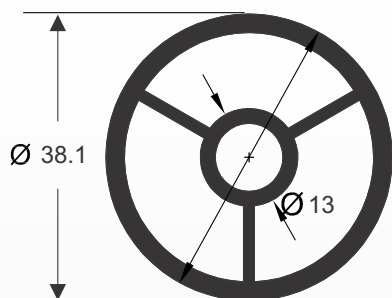

STL-0357

Merc. -----

Peso 0,443 kg/m

Descr. -----

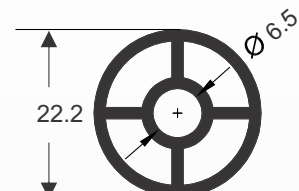

STL-0253

Merc. -----

Peso 0,120 kg/m

Descr. -----

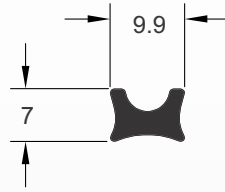

STL-1480

Merc. -----

Peso 0,603 kg/m

Descr. -----

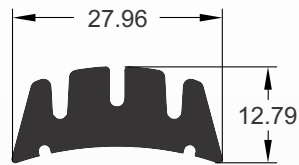

STL-0171

Merc. -----

Peso 0,482 kg/m

Descr. -----

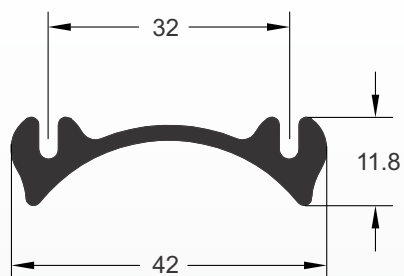

STL-1462

Merc. -----

Peso 0,759 kg/m

Descr. -----

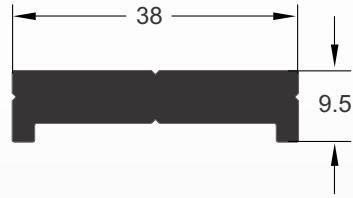

STL-0353

Merc. -----

Peso 1,005 kg/m

Descr. -----

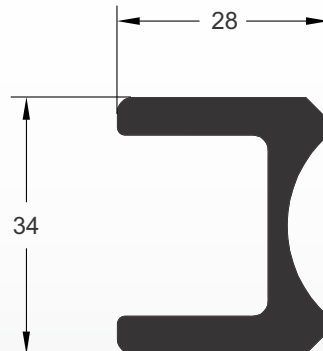

STL-0616

Merc. -----

Peso 0,829 kg/m

Descr. -----

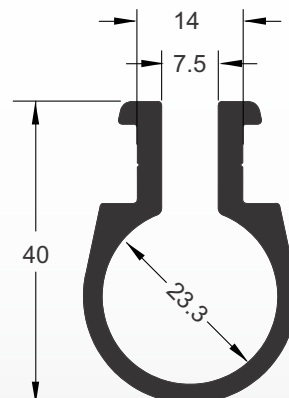

STL-0678

Merc. -----

Peso 0,147 kg/m

Descr. -----

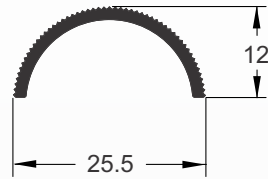

STL-0209

Merc. -----

Peso 0,285 kg/m

Descr. -----

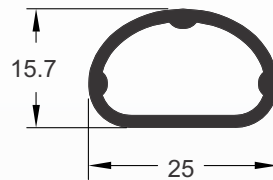

STL-0256

Merc. -----

Peso 0,604 kg/m

Descr. -----

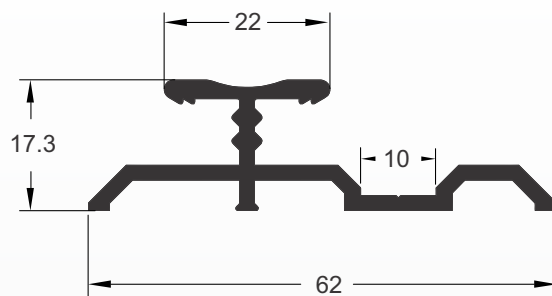

LEX-0039

Merc. -----

Peso 2,330 kg/m

Descr. -----



STL-0205

Merc. -----

Peso 0,491 kg/m

Descr. -----

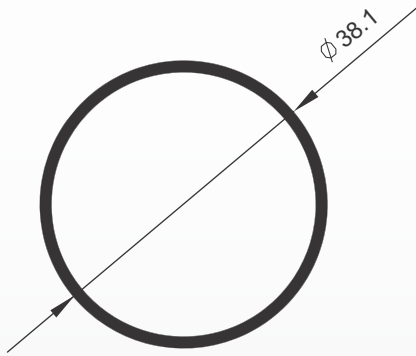

STL-0326

Merc. -----

Peso 0,278 kg/m

Descr. -----

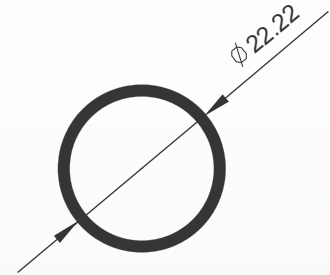

STL-0717

Merc. -----

Peso 0,662 kg/m

Descr. -----

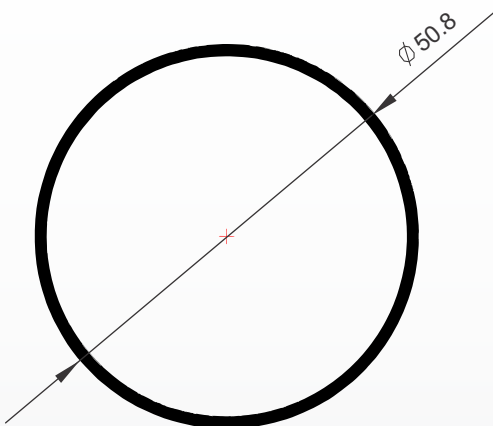

STL-1630

Merc. -----

Peso 1,287 kg/m

Descr. -----

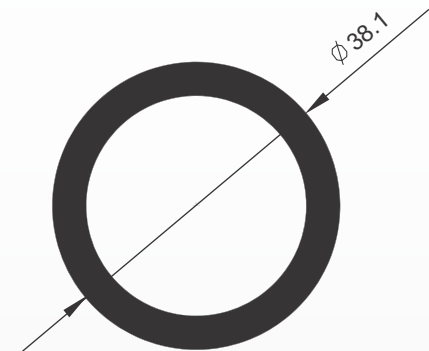

STL-1646

Merc. -----

Peso 1,594 kg/m

Descr. -----

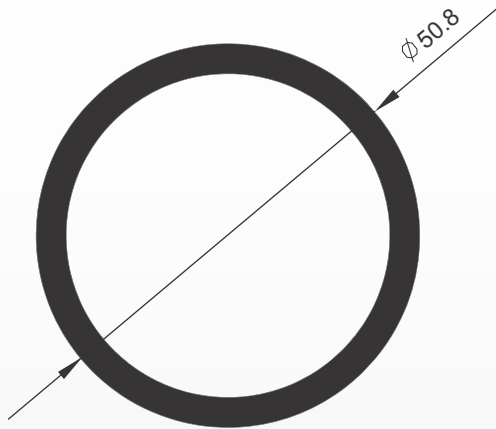

STL-1735

Merc. -----

Peso 0,507 kg/m

Descr. -----

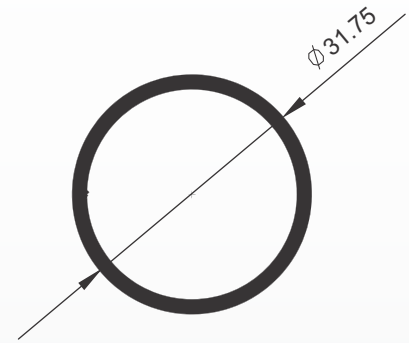

STL-1752

Merc. -----

Peso 1,746 kg/m

Descr. -----

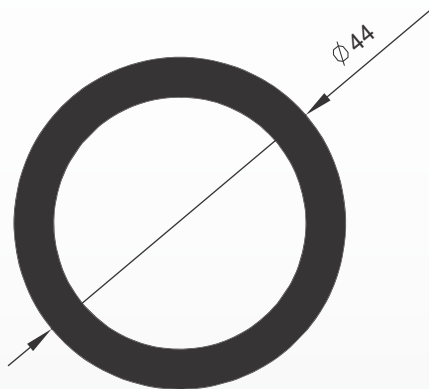

STL-1756

Merc. -----

Peso 2,077 kg/m

Descr. -----

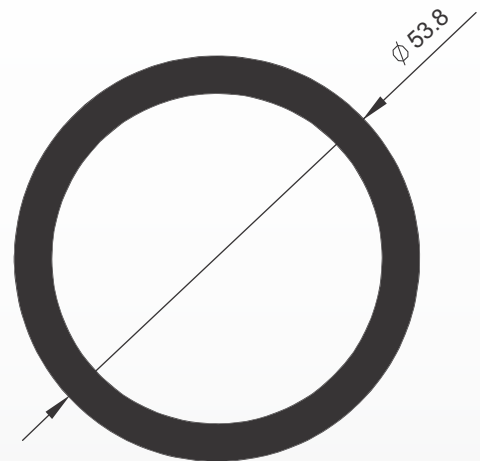

STL-1849

Merc. -----

Peso 0,281 kg/m

Descr. -----

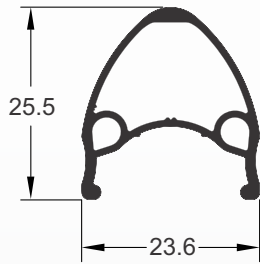

STL-1627

Merc. -----

Peso 0,624 kg/m

Descr. -----

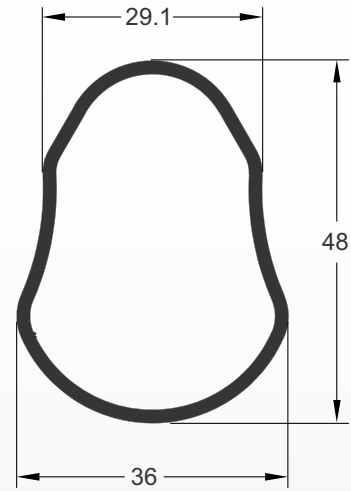

STL-1927

Merc. -----

Peso 0,519 kg/m

Descr. -----

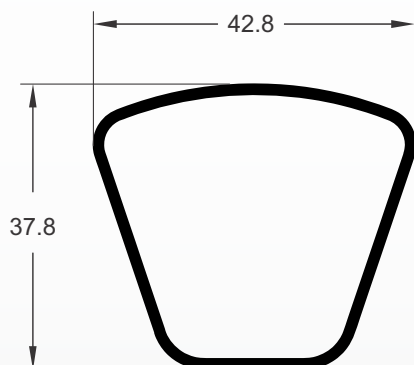

STL-1928

Merc. -----

Peso 0,748 kg/m

Descr. -----

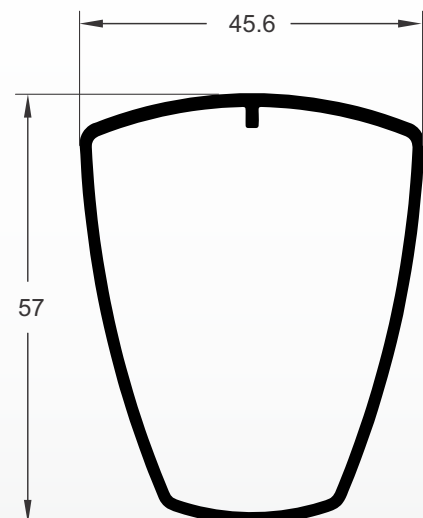



STL
ALUMÍNIO



stlaluminio.com.br



Av. Industrial, 1500 - Distrito Industrial - CEP 08586-150
Itaquaquecetuba - SP - Tel.: 55+ 11 4233-9012