



STL
ALUMÍNIO

LINHA

**CÂMERA DE
SEGURANÇA**

PERFIL EXTRUDADO DE ALUMÍNIO

CATÁLOGO Ver 1.0 | DEZ 24

PERFIL	MERCADO	KG/M	PÁG.
STL-0839	—	0,379	03
STL-0840	—	0,818	04
STL-0855	—	0,646	03
STL-0856	—	1,323	04

STL-0839

Merc. -----

Peso 0,379 kg/m

Descr. -----

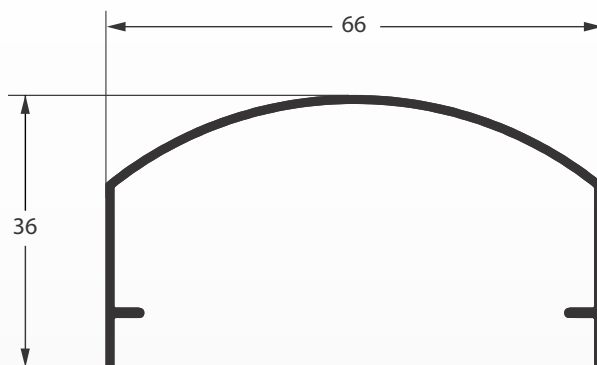

STL-0855

Merc. -----

Peso 0,646 kg/m

Descr. -----

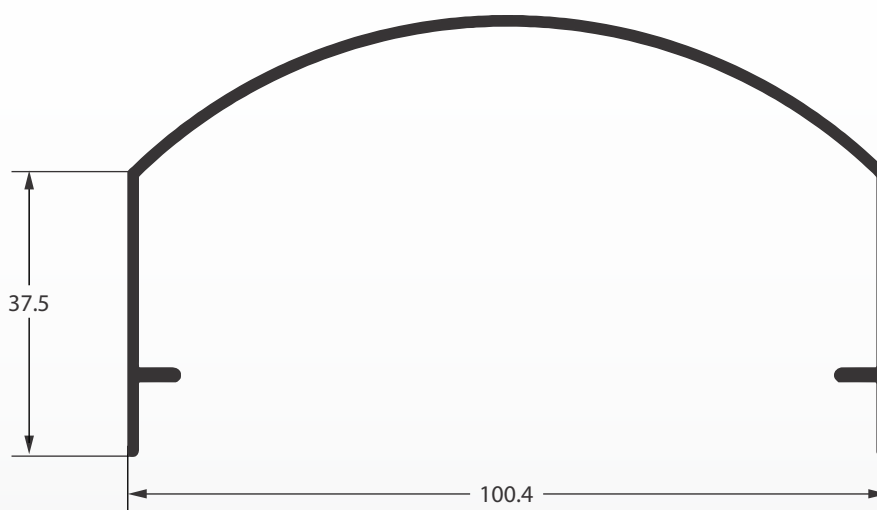

STL-0840

Merc. -----

Peso 0,818 kg/m

Descr. -----

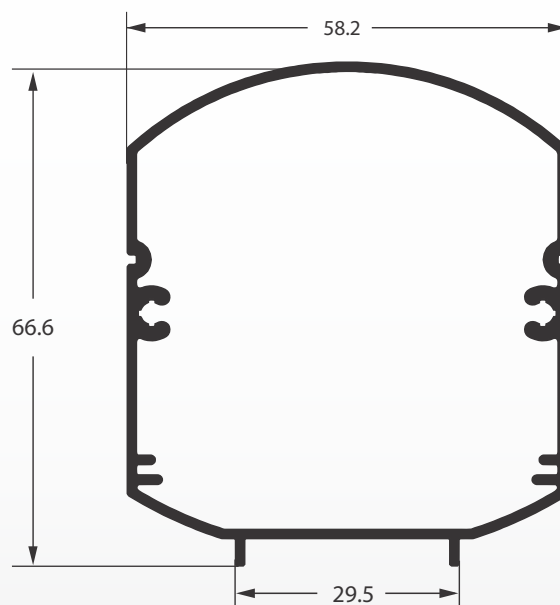

STL-0856

Merc. -----

Peso 1,323 kg/m

Descr. -----

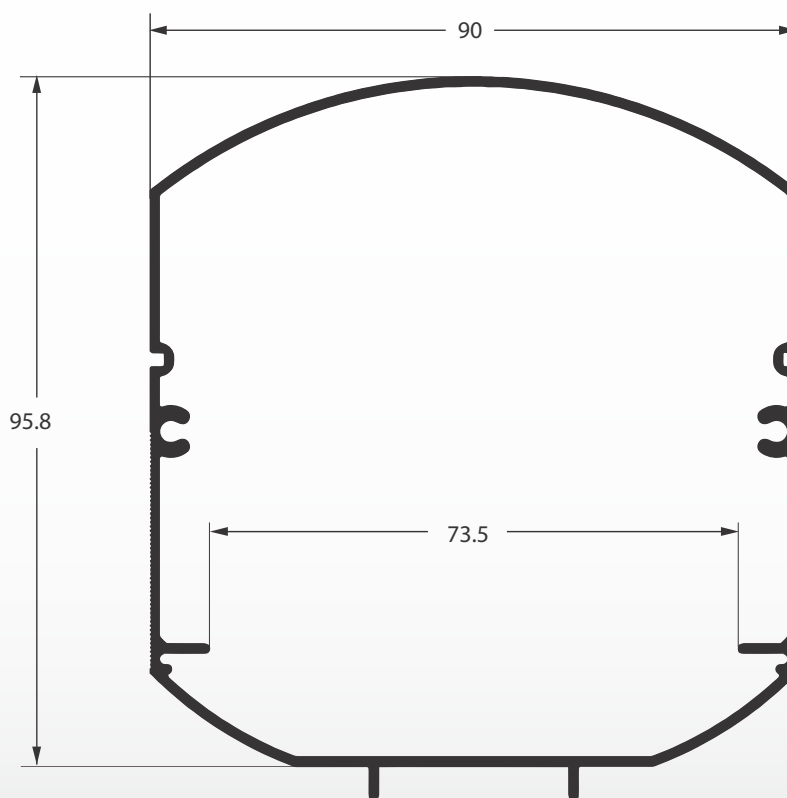



STL
ALUMÍNIO



stlaluminio.com.br



Av. Industrial, 1500 - Distrito Industrial - CEP 08586-150
Itaquaquecetuba - SP - Tel.: 55+ 11 4233-9012