



STL
ALUMÍNIO

LINHA

**IMPLEMENTOS
RODOVIÁRIOS**

PERFIL EXTRUDADO DE ALUMÍNIO

CATÁLOGO Ver 1.0 | DEZ 24

PERFIL	MERCADO	KG/M	PÁG.
STL-0037	—	0,481	24
STL-0038	—	0,557	24
STL-0039	—	1,151	58
STL-0040	—	0,940	60
STL-0041	—	0,730	29
STL-0042	—	0,834	27
STL-0043	—	0,615	05
STL-0044	—	0,591	23
STL-0045	—	0,126	32
STL-0062	—	0,441	24
STL-0063	—	0,683	29
STL-0069	—	1,065	14
STL-0070	—	0,526	63
STL-0121	—	0,884	62
STL-0122	—	0,538	63
STL-0243	—	0,575	05
STL-0312	—	0,595	61
STL-0320	—	0,471	33
STL-0321	—	0,882	46
STL-0345	—	1,598	18
STL-0346	—	2,009	19
STL-0347	—	2,186	67
STL-0348	—	2,601	67
STL-0372	—	1,337	20
STL-0373	—	0,730	57
STL-0374	—	0,562	57
STL-0375	—	1,357	68
STL-0376	—	0,967	68
STL-0377	—	0,978	16
STL-0392	—	1,072	61
STL-0393	—	0,970	60
STL-0455	—	0,491	33
STL-0460	—	1,934	15
STL-0617	—	1,716	12
STL-0647	—	1,792	12
STL-0648	—	0,917	06
STL-0660	—	1,787	91
STL-0661	—	0,883	30
STL-0662	—	1,173	69
STL-0663	—	1,408	20
STL-0664	—	0,696	23
STL-0667	—	0,799	26
STL-0668	—	1,020	59
STL-0669	—	2,125	21
STL-0670	—	1,726	70
STL-0671	—	1,937	71
STL-0672	—	2,165	72
STL-0673	—	1,158	44

PERFIL	MERCADO	KG/M	PÁG.
STL-0674	—	0,159	32
STL-0682	—	1,639	73
STL-0683	—	1,366	74
STL-0684	—	0,477	33
STL-0719	—	1,974	75
STL-0732	—	0,762	04
STL-0733	—	0,889	58
STL-0736	—	1,805	79
STL-0794	—	1,334	76
STL-0795	—	1,868	77
STL-0807	—	1,036	08
STL-0821	—	2,339	78
STL-0836	—	0,529	28
STL-0895	—	1,855	43
STL-0896	—	0,540	47
STL-0897	—	3,388	56
STL-0898	—	0,149	32
STL-0899	—	3,144	43
STL-0902	—	1,248	48
STL-0932	—	1,769	54
STL-0933	—	0,928	52
STL-0934	—	1,300	52
STL-0935	—	0,764	53
STL-0937	—	2,684	42
STL-0942	—	1,076	45
STL-0946	—	0,355	91
STL-0969	—	0,617	31
STL-0970	—	0,615	65
STL-0971	—	1,333	09
STL-0973	—	0,618	04
STL-0974	—	1,723	85
STL-0975	—	0,748	06
STL-0976	—	1,466	22
STL-0977	—	0,970	47
STL-0981	—	0,203	46
STL-0982	—	0,997	59
STL-0983	—	0,694	46
STL-0988	—	4,286	41
STL-0990	—	2,171	38
STL-0991	—	0,978	91
STL-0994	—	1,585	18
STL-0995	—	1,300	87
STL-0996	—	1,781	86
STL-0997	—	1,094	37
STL-1027	—	0,535	50
STL-1028	—	1,550	35
STL-1029	—	1,057	13
STL-1030	—	0,154	32

PERFIL	MERCADO	KG/M	PÁG.
STL-1031	—	0,876	05
STL-1032	—	1,807	36
STL-1034	—	0,974	34
STL-1037	—	1,596	13
STL-1038	—	1,694	35
STL-1039	—	2,432	56
STL-1040	—	4,675	39
STL-1043	—	1,348	88
STL-1050	—	1,149	34
STL-1051	—	0,943	25
STL-1052	—	1,672	10
STL-1054	—	2,608	52
STL-1055	—	0,887	27
STL-1056	—	1,741	38
STL-1060	—	1,550	55
STL-1061	—	3,848	53
STL-1070	—	2,120	51
STL-1076	—	1,035	08
STL-1137	—	0,558	23
STL-1143	—	0,474	31
STL-1148	—	0,626	33
STL-1173	—	1,697	80
STL-1181	—	0,445	25
STL-1182	—	1,463	81
STL-1183	—	0,666	28
STL-1184	—	1,261	82
STL-1185	—	0,428	64
STL-1186	—	1,168	14
STL-1187	—	0,438	04
STL-1188	—	1,692	10
STL-1189	—	1,030	62
STL-1201	—	0,609	40
STL-1202	—	0,787	40
STL-1203	—	2,070	50
STL-1206	—	1,037	40
STL-1254	—	0,726	32
STL-1256	—	1,208	37
STL-1258	—	1,528	66
STL-1316	—	0,880	26
STL-1317	—	2,463	89
STL-1318	—	1,551	89
STL-1319	—	0,903	30
STL-1320	—	0,917	30
STL-1321	—	1,189	17
STL-1322	—	0,120	32
STL-1323	—	0,665	65
STL-1324	—	1,965	83
STL-1325	—	1,734	84

PERFIL	MERCADO	KG/M	PÁG.
STL-1326	—	2,228	19
STL-1327	—	1,373	90
STL-1382	—	2,466	69
STL-1407	—	2,100	41
STL-1607	—	3,156	42
STL-1702	—	0,788	54
STL-1764	—	1,404	49
STL-1807	—	0,970	49
STL-1838	—	0,689	47
STL-1839	—	0,933	11
STL-1840	—	1,570	07
STL-1864	—	1,353	92

STL-1187

Merc. -----

Peso 0,438 kg/m

Descr. -----

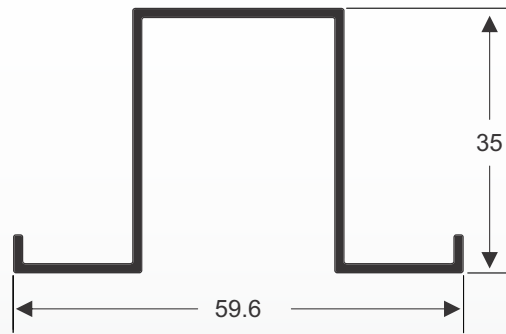

STL-0973

Merc. -----

Peso 0,618 kg/m

Descr. -----

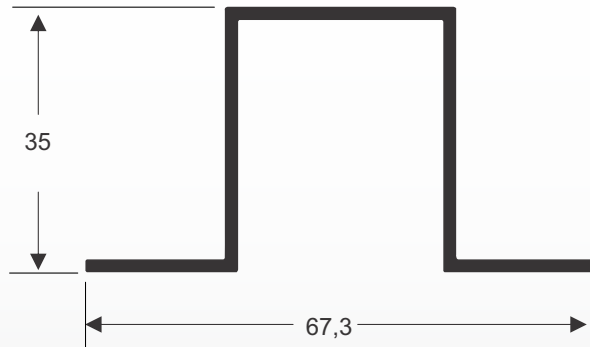

STL-0732

Merc. -----

Peso 0,762 kg/m

Descr. -----

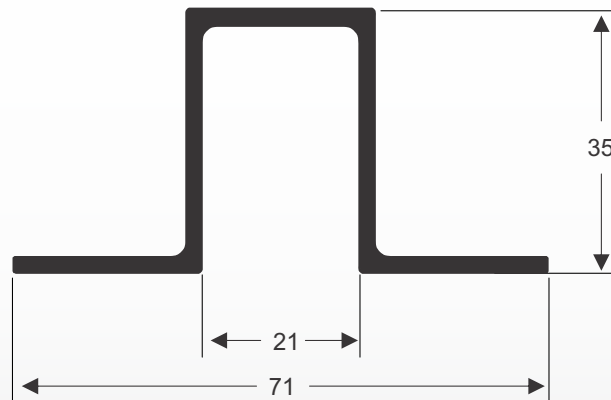

STL-0043

Merc. -----

Peso 0,615 kg/m

Descr. -----

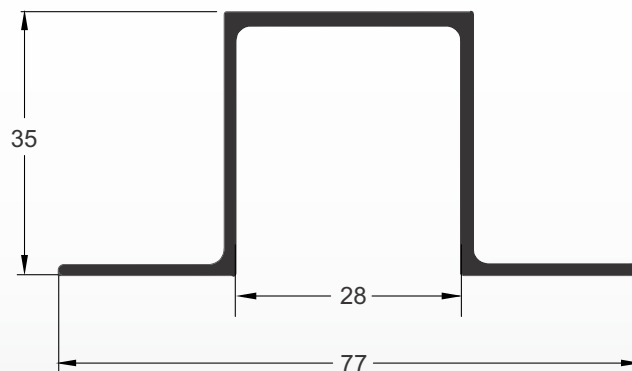

STL-0243

Merc. -----

Peso 0,575 kg/m

Descr. -----

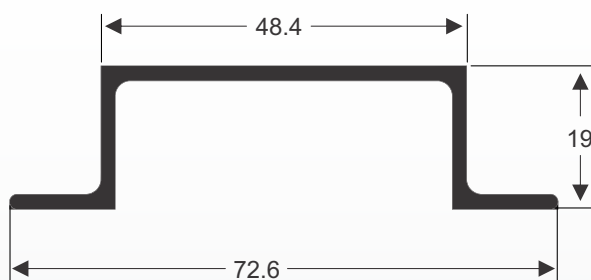

STL-1031

Merc. -----

Peso 0,876 kg/m

Descr. -----

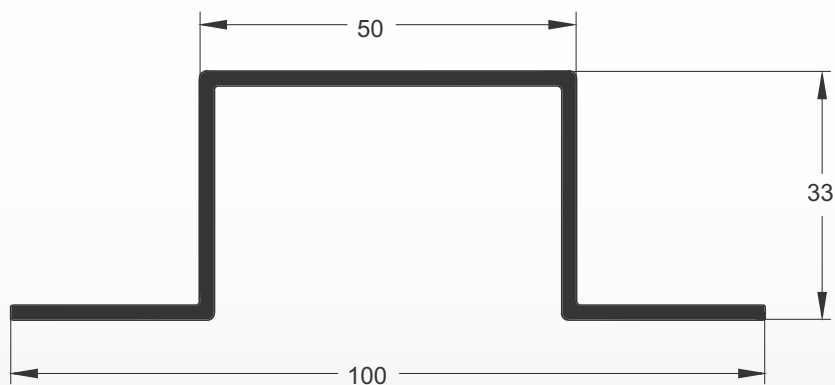

STL-0975

Merc. -----

Peso 0,748 kg/m

Descr. -----

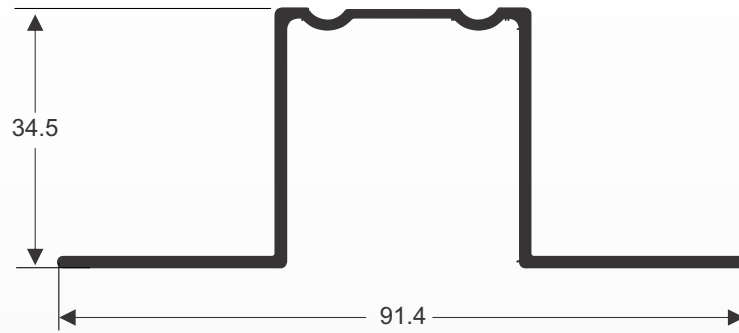

STL-0648

Merc. -----

Peso 0,917 kg/m

Descr. -----

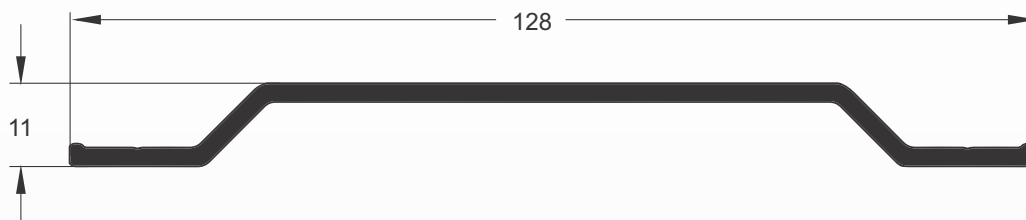

STL-1840

Merc. -----

Peso **1,570** kg/m

Descr. -----

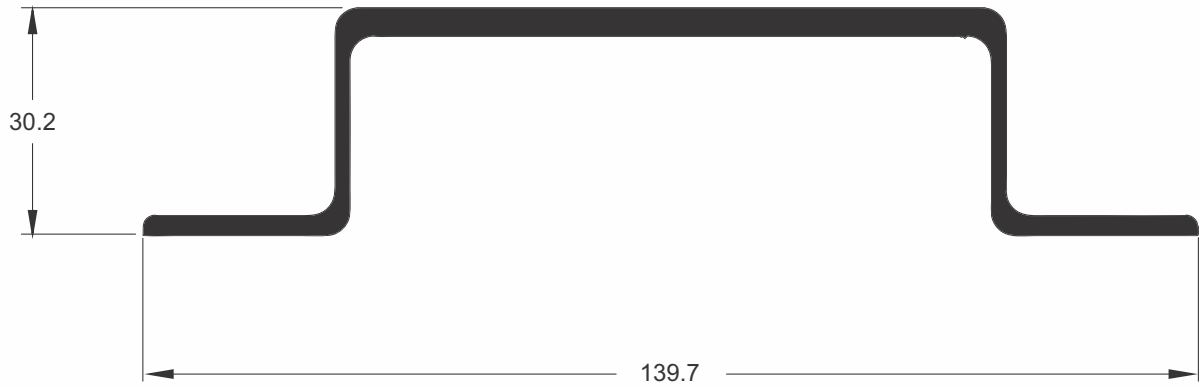

STL-0807

Merc. -----

Peso 1,036 kg/m

Descr. -----

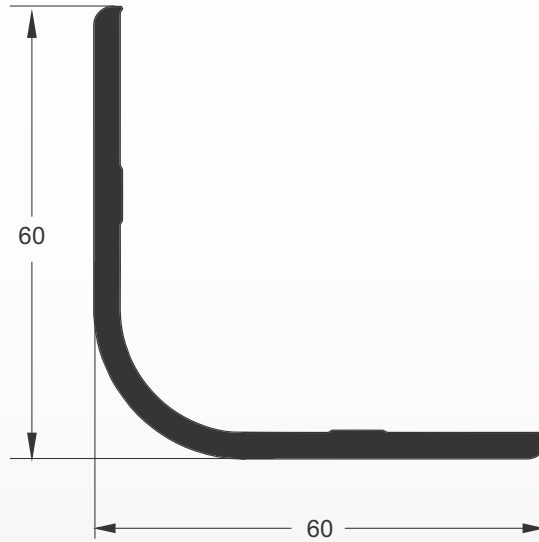

STL-1076

Merc. -----

Peso 1,035 kg/m

Descr. -----

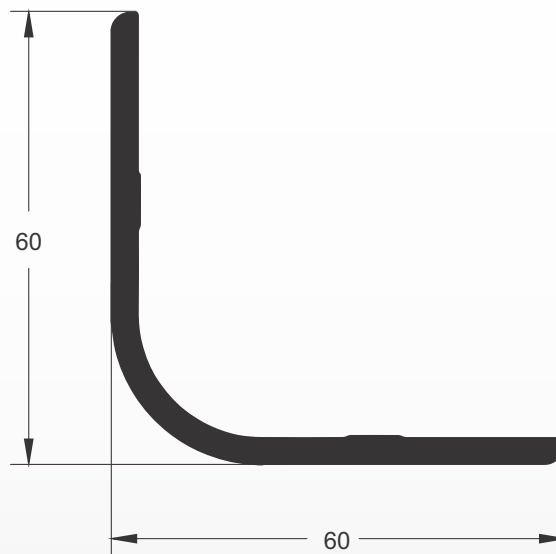

STL-0971

Merc. -----

Peso 1,333 kg/m

Descr. -----

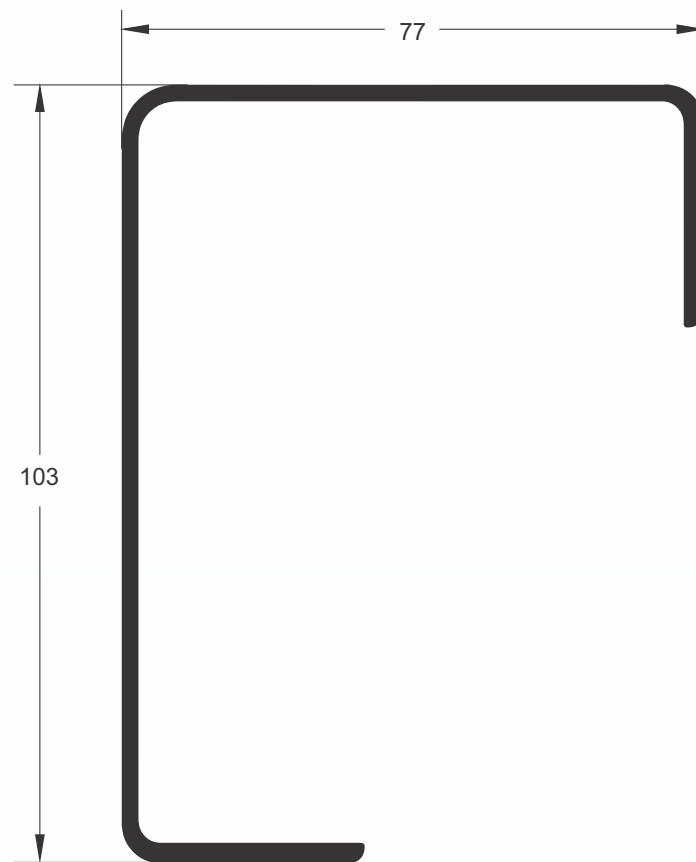

STL-1052

Merc. -----

Peso 1,672 kg/m

Descr. -----

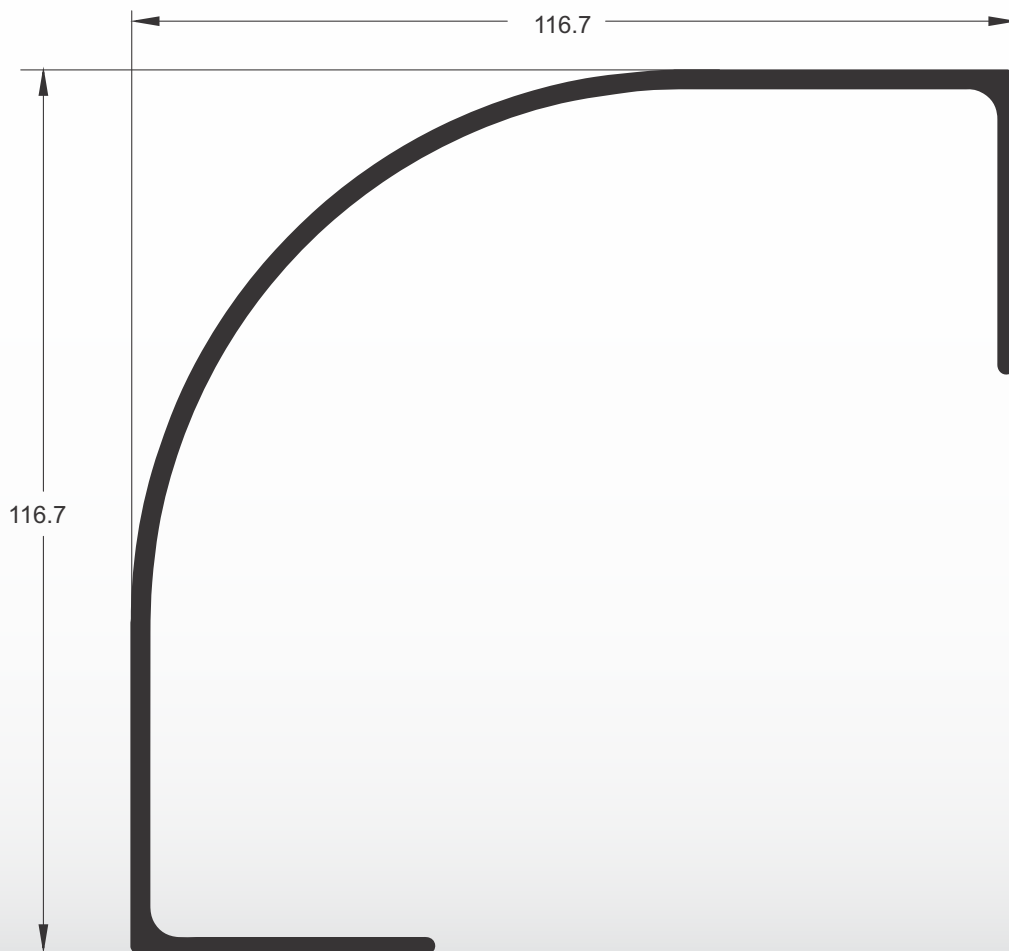

STL-1188

Merc. -----

Peso 1,692 kg/m

Descr. -----

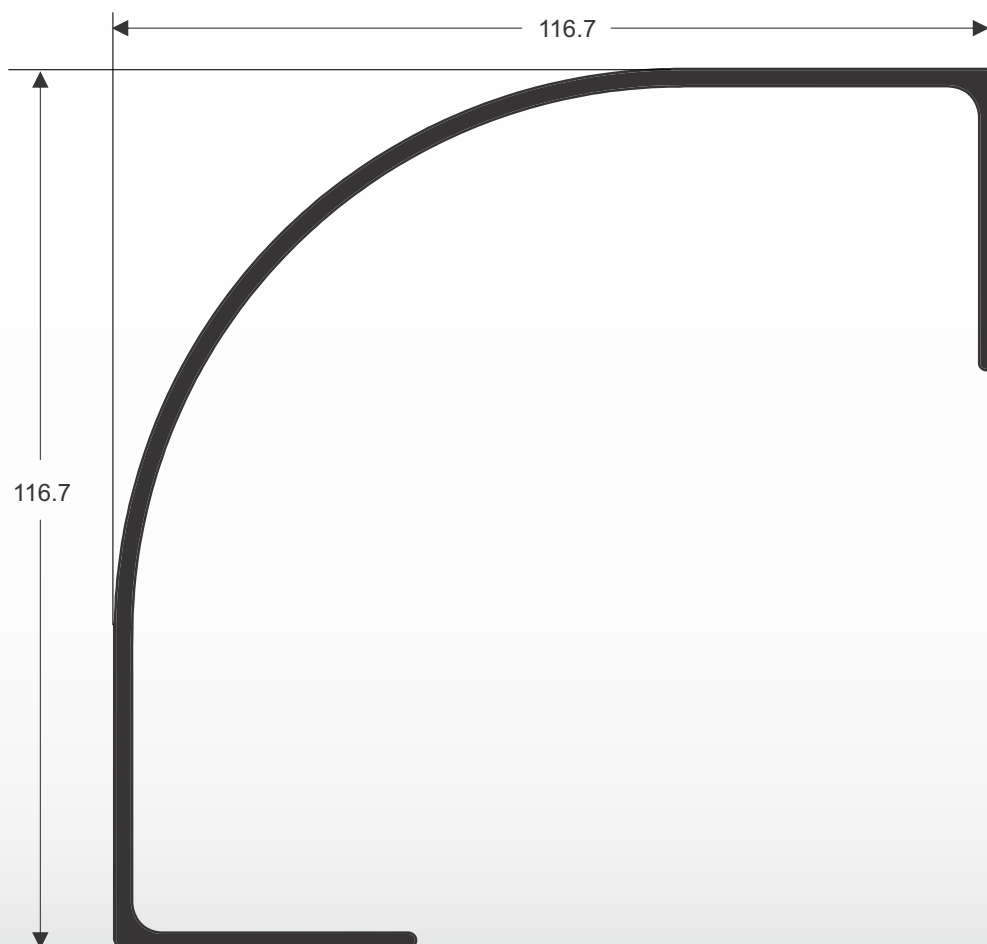

STL-1839

Merc. -----

Peso 0,933 kg/m

Descr. -----

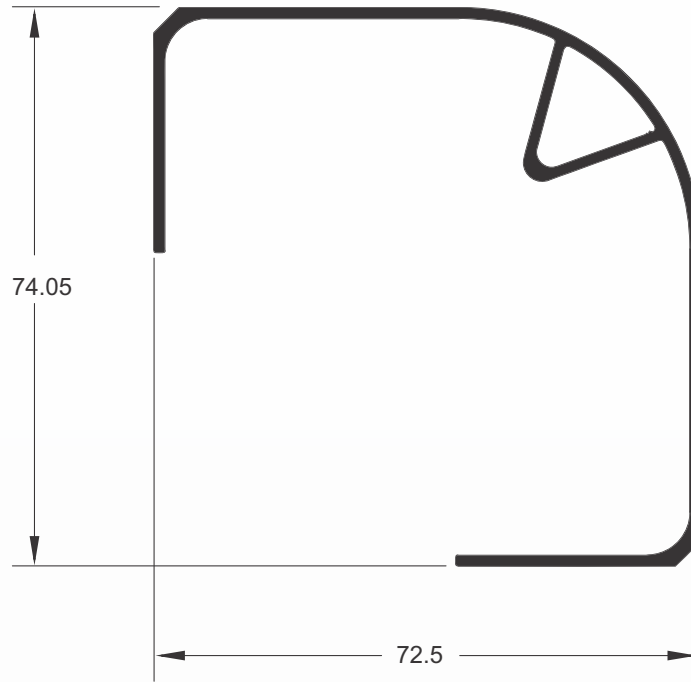

STL-0617

Merc. -----

Peso 1,716 kg/m

Descr. -----

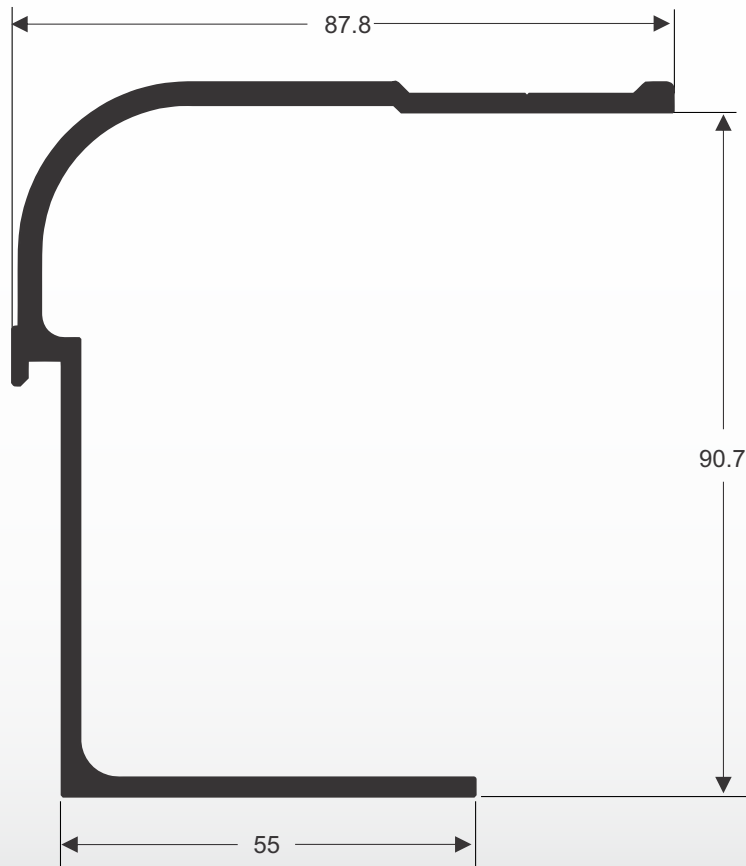

STL-0647

Merc. -----

Peso 1,792 kg/m

Descr. -----

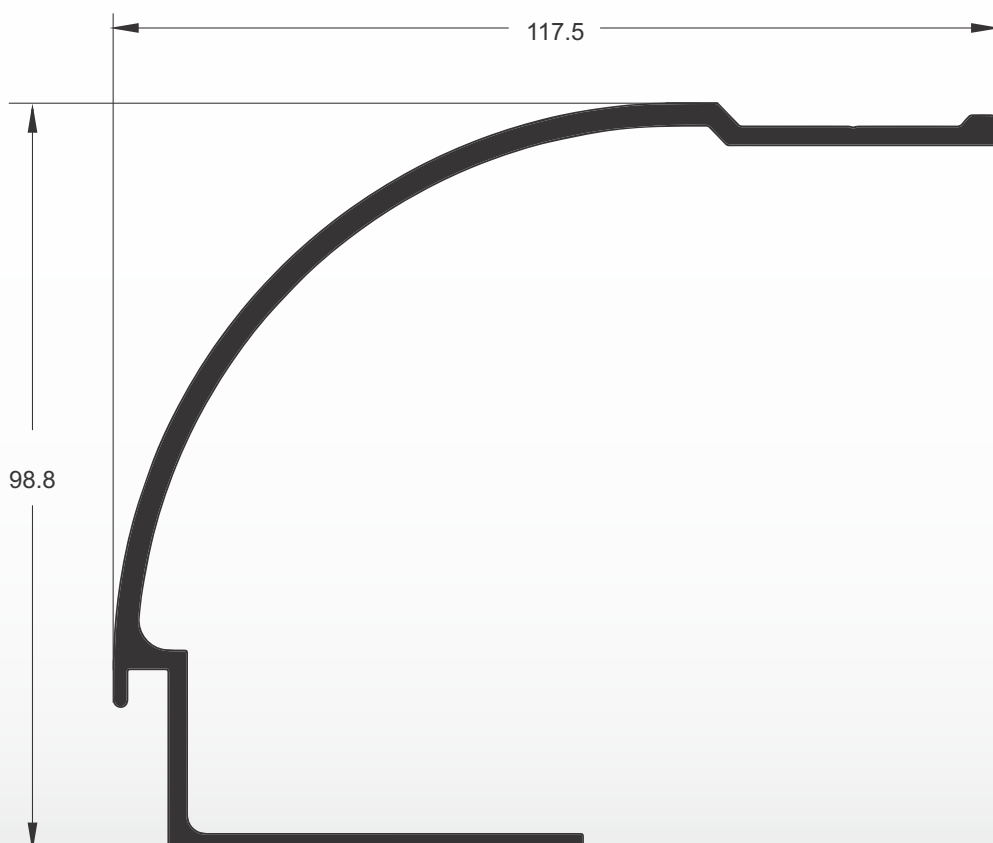

STL-1029

Merc.-----

Peso 1,057 kg/m

Descr.-----

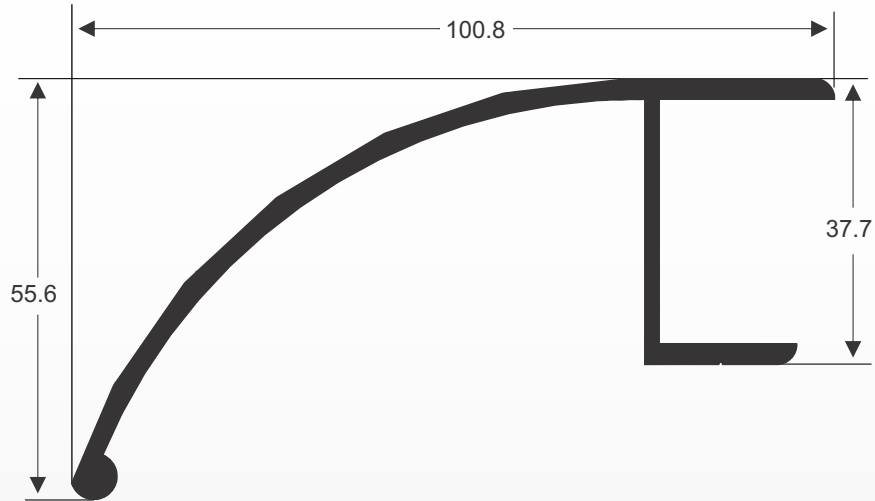

STL-1037

Merc.-----

Peso 1,596 kg/m

Descr.-----

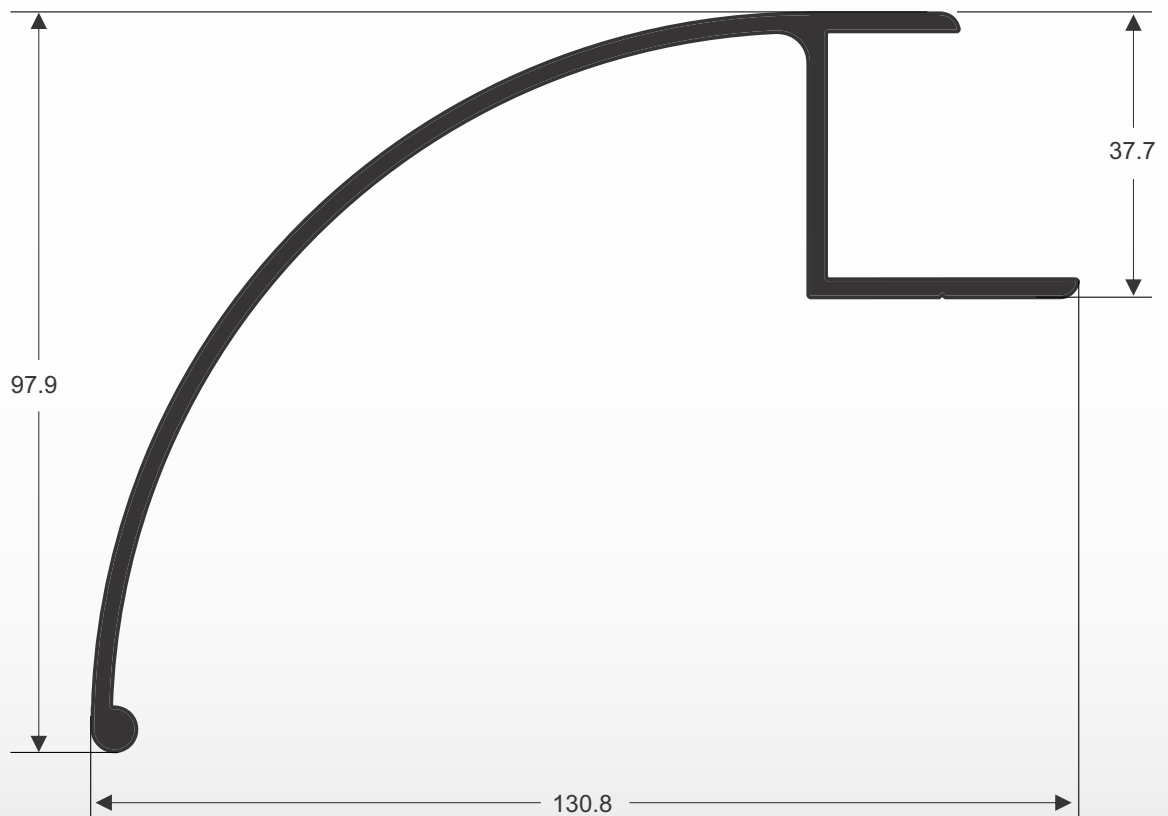

STL-0069

Merc. -----

Peso 1,065 kg/m

Descr. -----

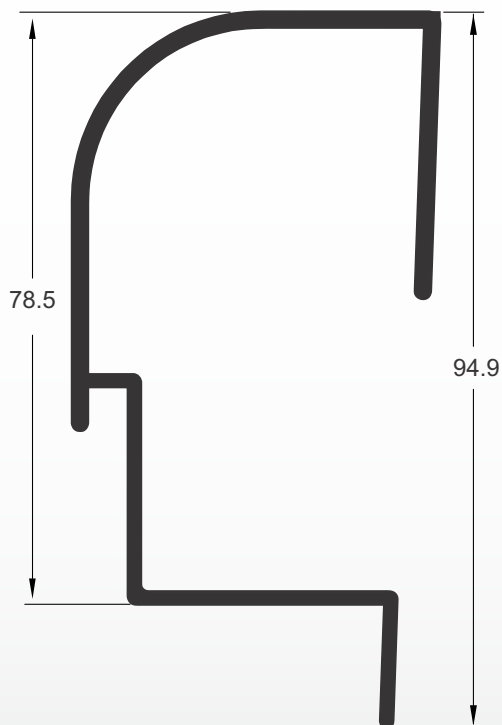

STL-1186

Merc. -----

Peso 1,168 kg/m

Descr. -----

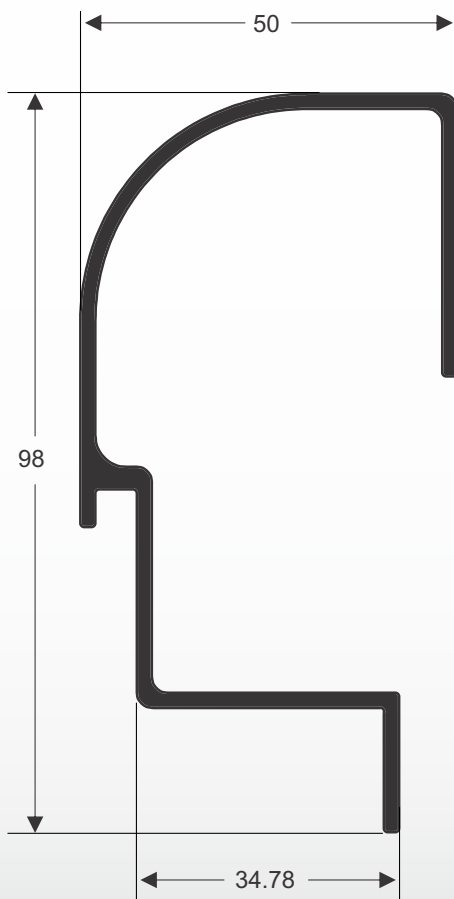

STL-0460

Merc. -----

Peso 1,934 kg/m

Descr. -----

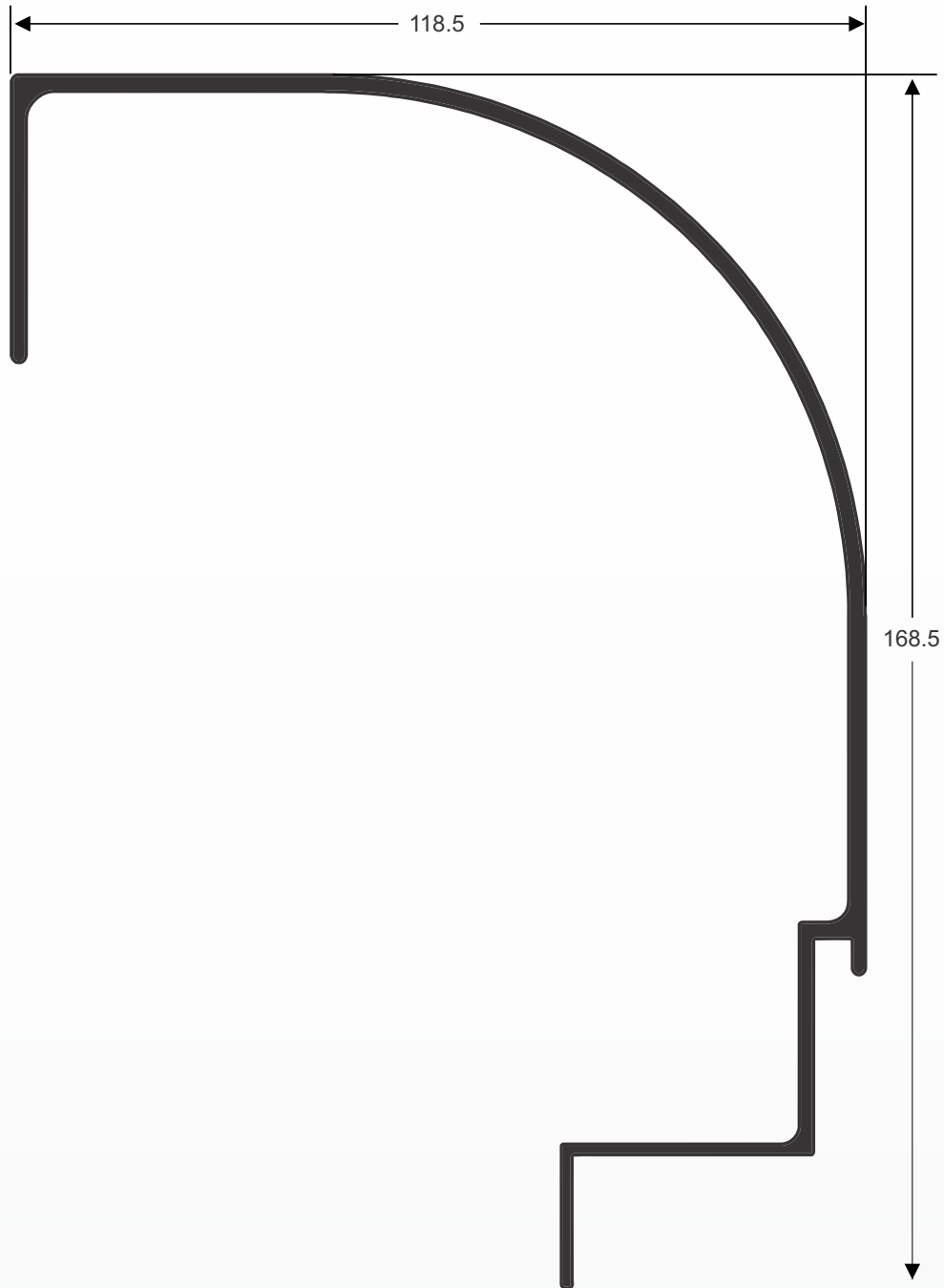

STL-0377

Merc. -----

Peso 0,978 kg/m

Descr. -----

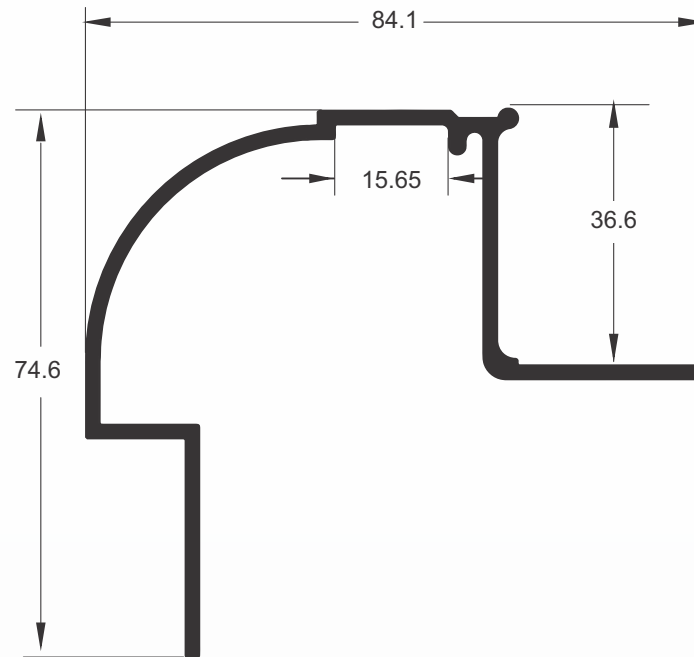

STL-1321

Merc.-----

Peso 1,189 kg/m

Descr.-----

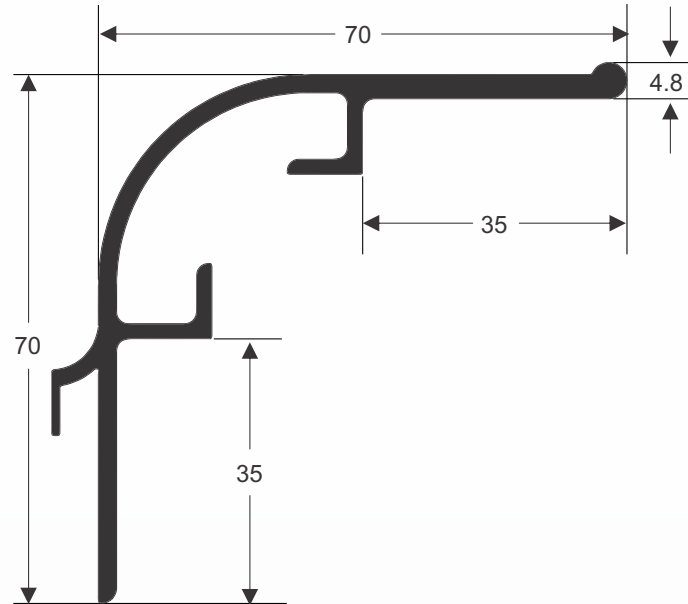

STL-0994

Merc. -----

Peso 1,585 kg/m

Descr. -----

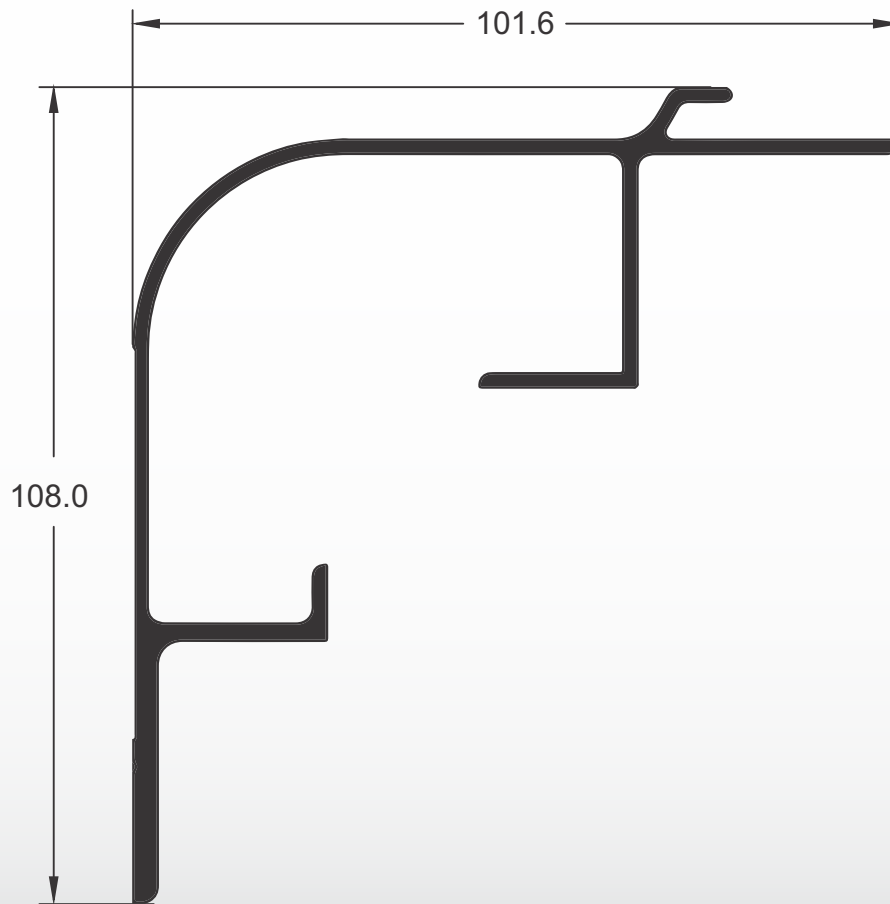

STL-0345

Merc. -----

Peso 1,598 kg/m

Descr. -----

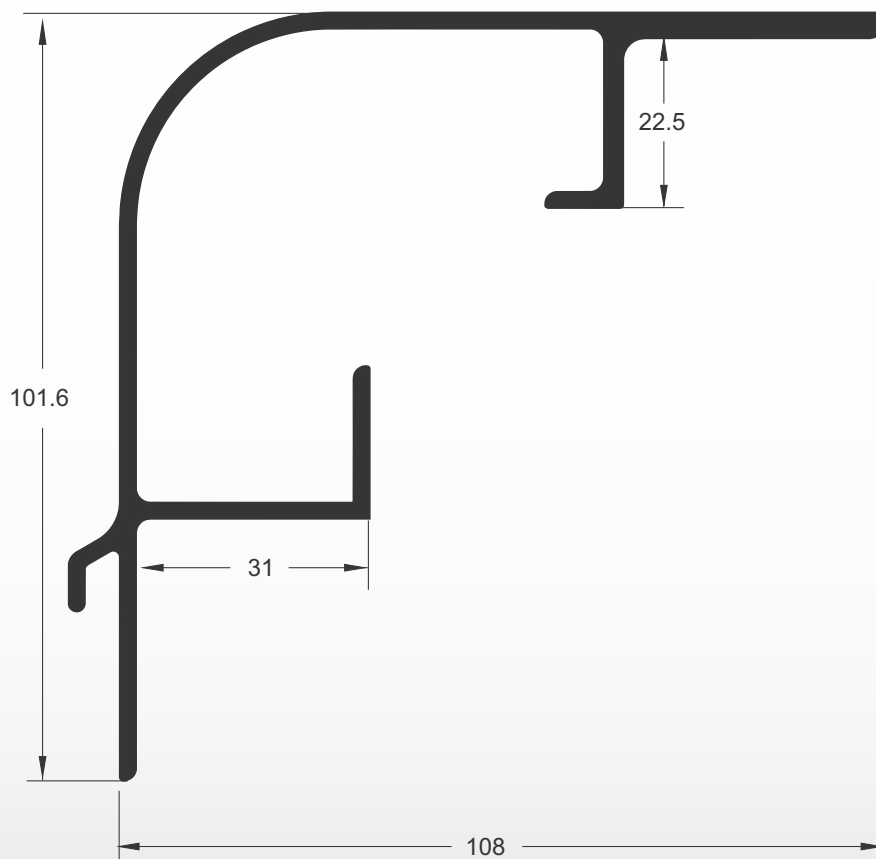

STL-0346

Merc. -----

Peso 2,009 kg/m

Descr. -----

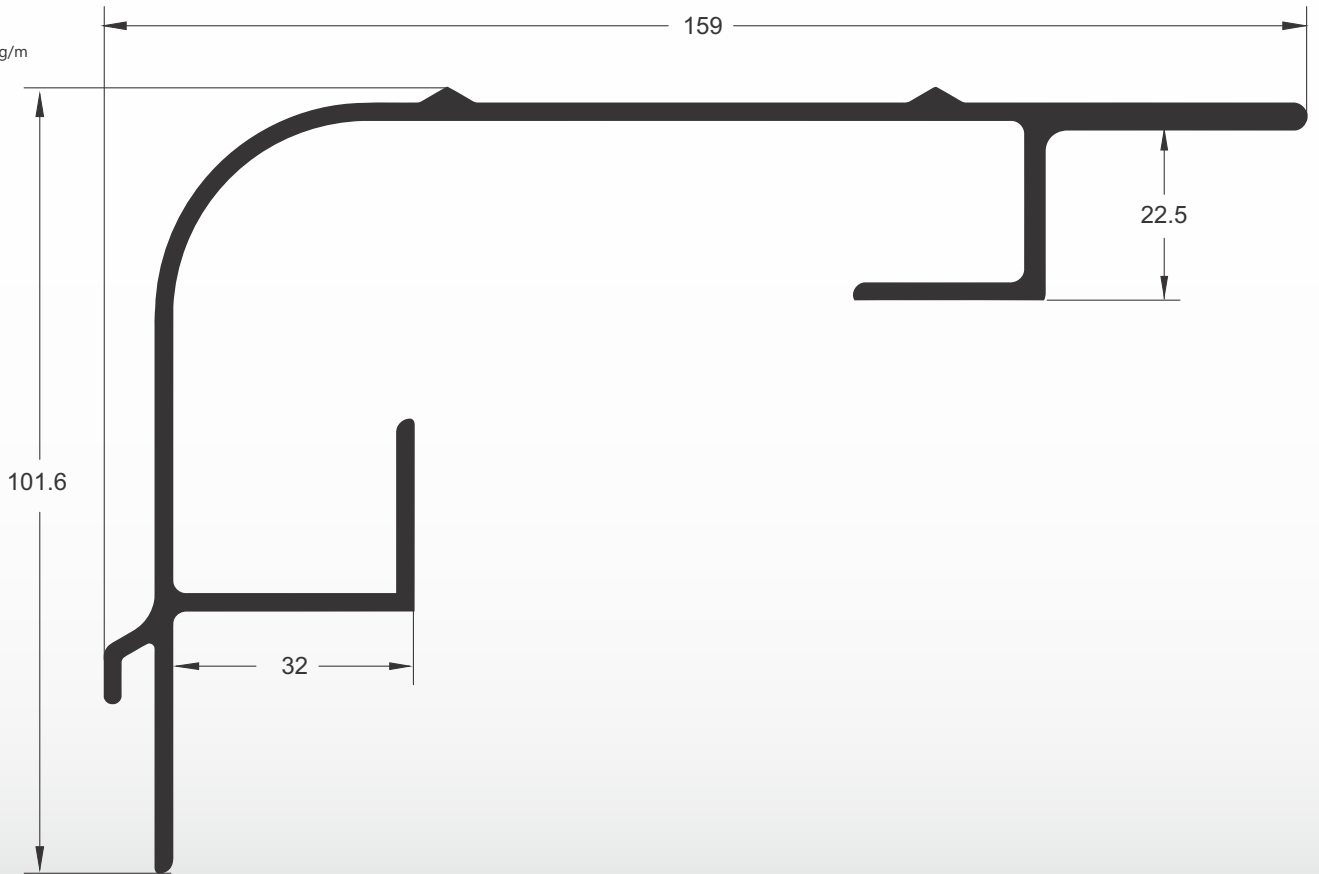

STL-1326

Merc. -----

Peso 2,228 kg/m

Descr. -----

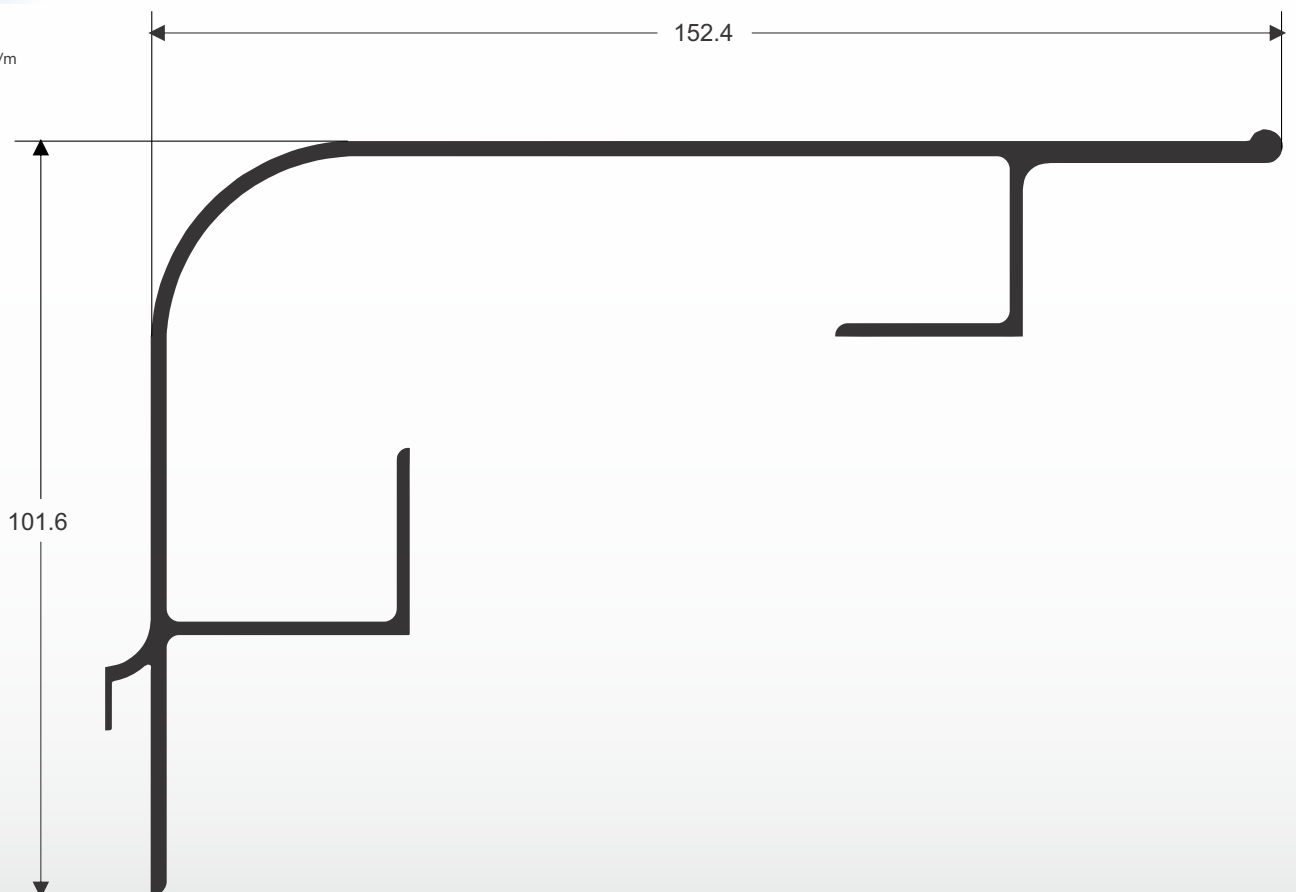

STL-0372

Merc. -----

Peso 1,337 kg/m

Descr. -----

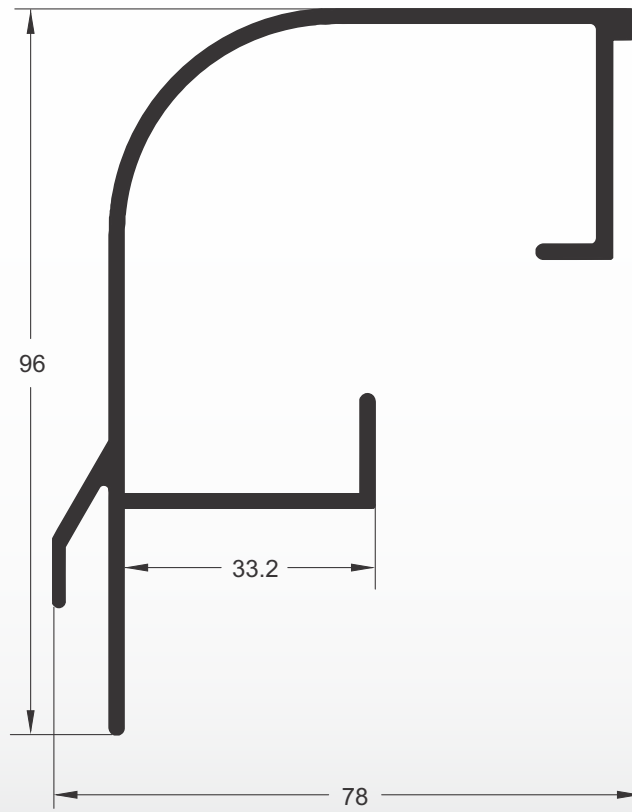

STL-0663

Merc. -----

Peso 1,408 kg/m

Descr. -----

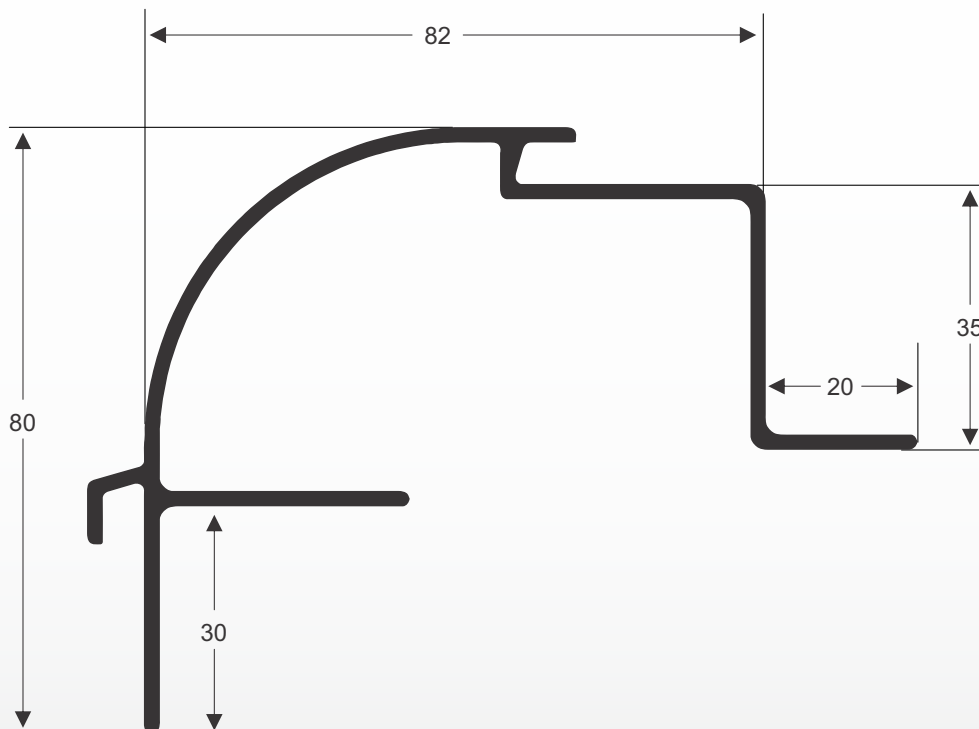

STL-0669

Merc. -----

Peso 2,125 kg/m

Descr. -----

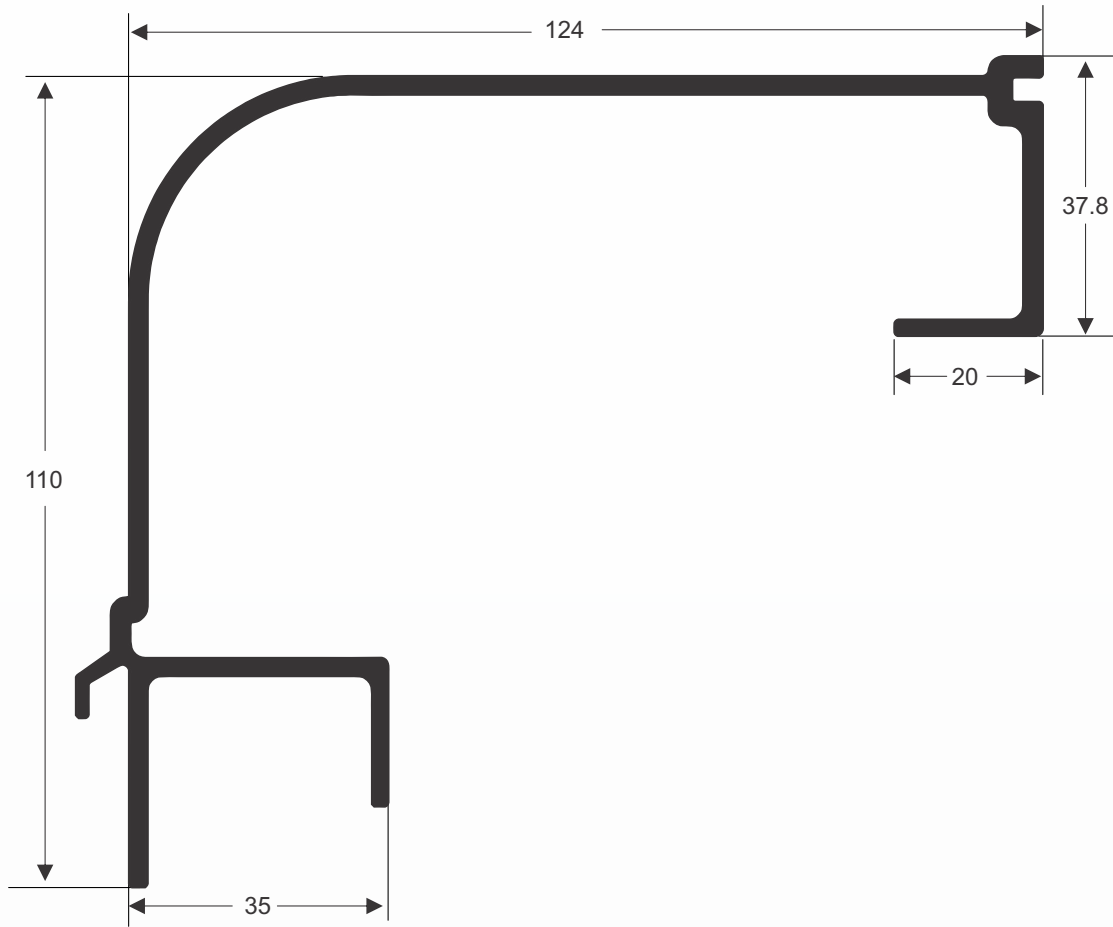

STL-0976

Merc.-----

Peso 1,466 kg/m

Descr.-----

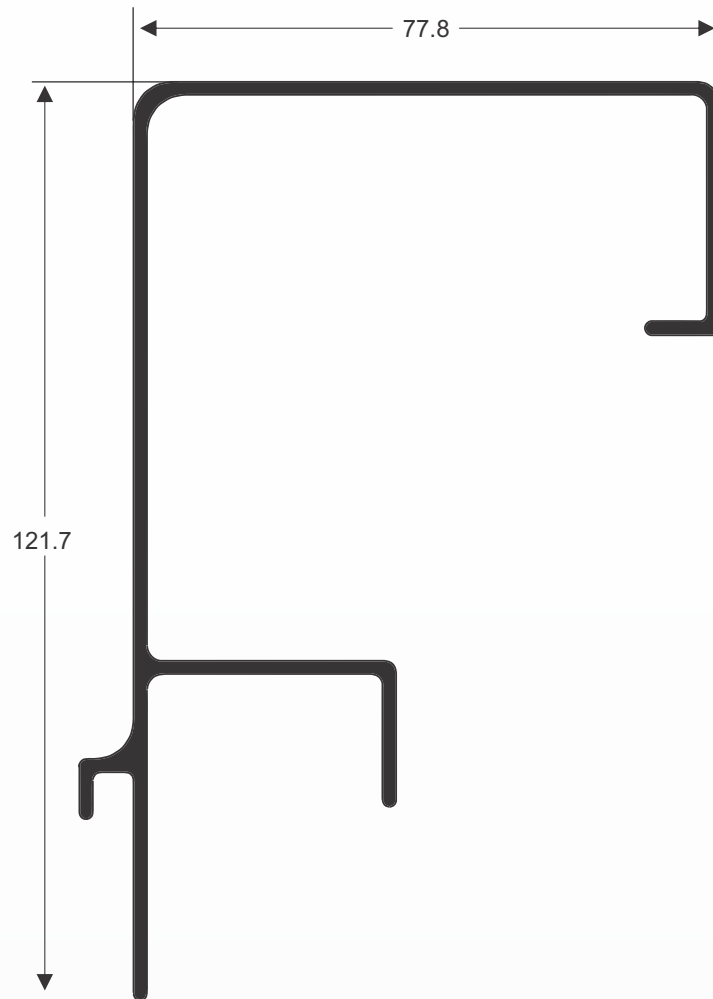

STL-0044

Merc. -----

Peso 0,591 kg/m

Descr. -----

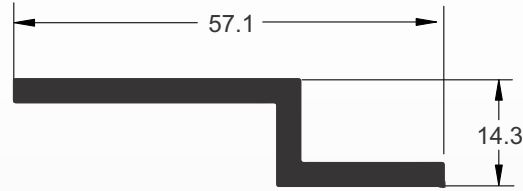

STL-0664

Merc. -----

Peso 0,696 kg/m

Descr. -----

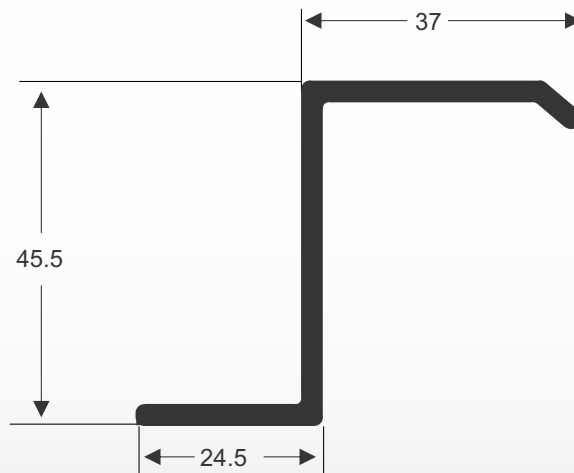

STL-1137

Merc. -----

Peso 0,558 kg/m

Descr. -----

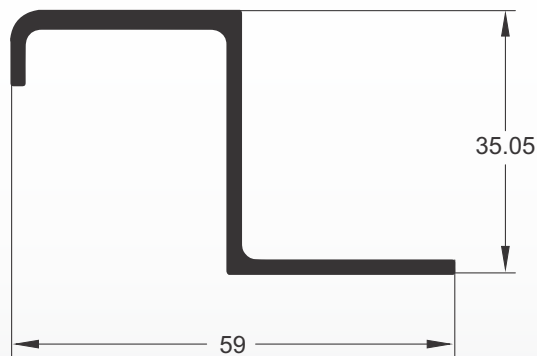

STL-0062

Merc. -----

Peso 0,441 kg/m

Descr. -----
Correr 2

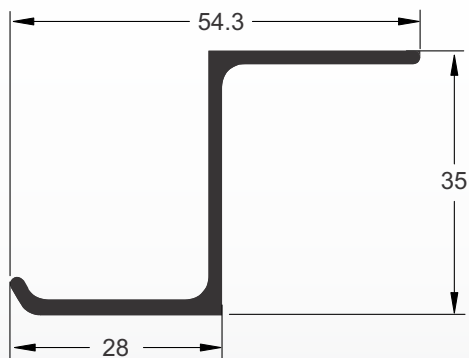

STL-0037

Merc. -----

Peso 0,481 kg/m

Descr. -----

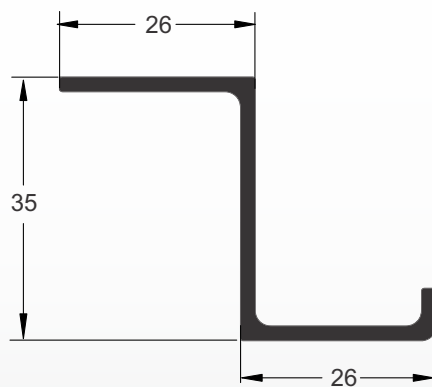

STL-0038

Merc. -----

Peso 0,557 kg/m

Descr. -----

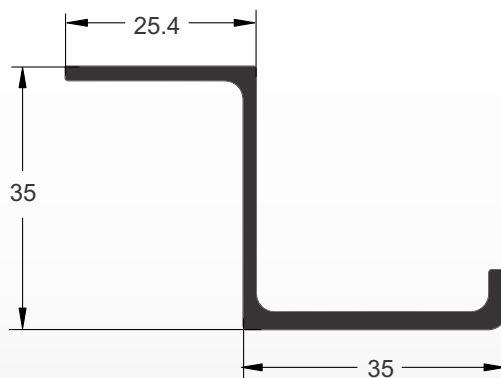

STL-1051

Merc. -----

Peso 0,943 kg/m

Descr. -----

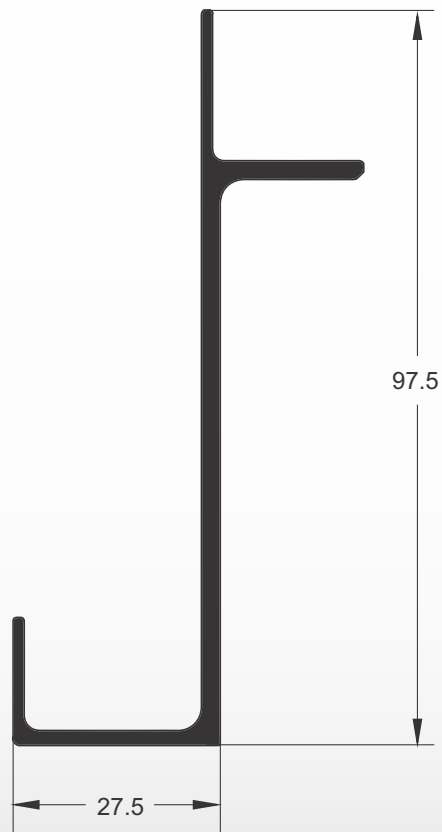

STL-1181

Merc. -----

Peso 0,445 kg/m

Descr. -----

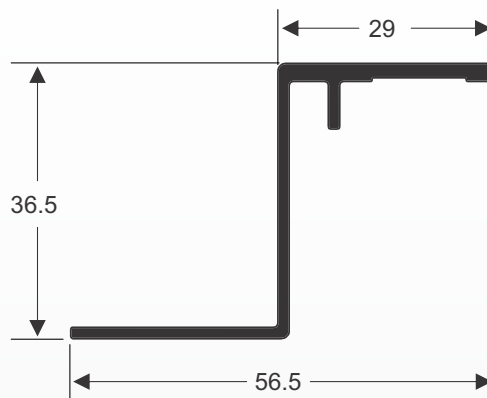

STL-0667

Merc. -----

Peso 0,799 kg/m

Descr. -----

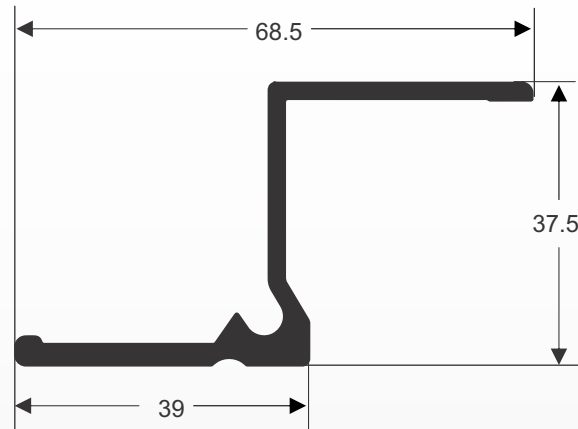

STL-1316

Merc. -----

Peso 0,880 kg/m

Descr. -----

Correr 2

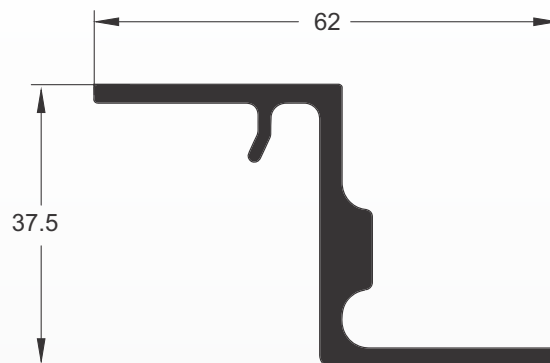

STL-0042

Merc.-----

Peso 0,834 kg/m

Descr.-----

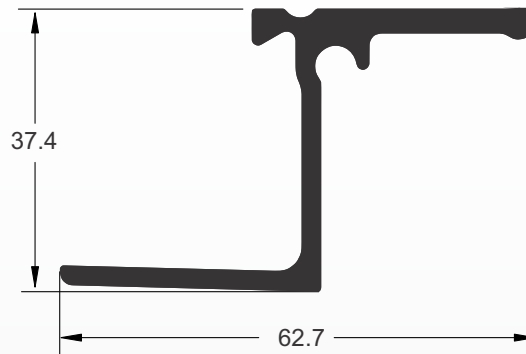

STL-1055

Merc.-----

Peso 0,887 kg/m

Descr.-----

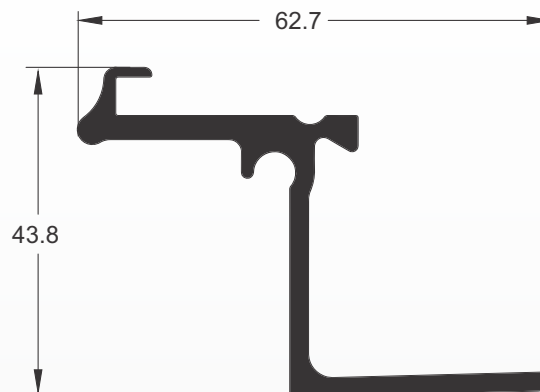

STL-1183

Merc. -----

Peso 0,666 kg/m

Descr. -----

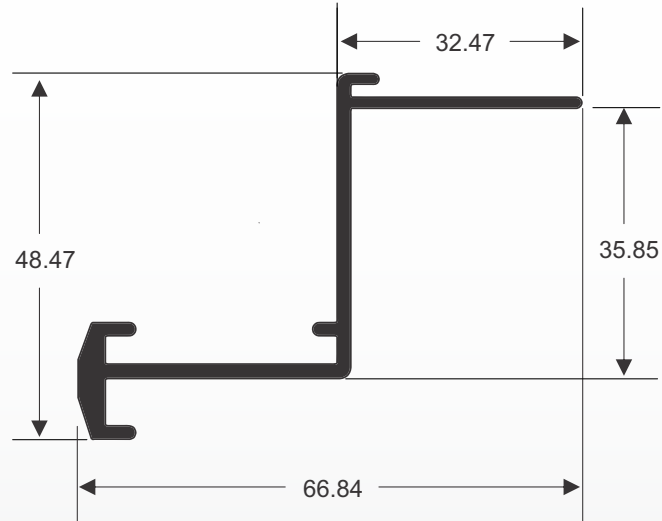

STL-0836

Merc. -----

Peso 0,529 kg/m

Descr. -----

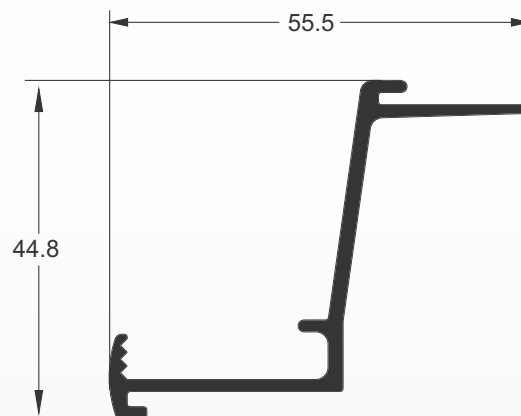

STL-0063

Merc.-----

Peso 0,683 kg/m

Descr.-----

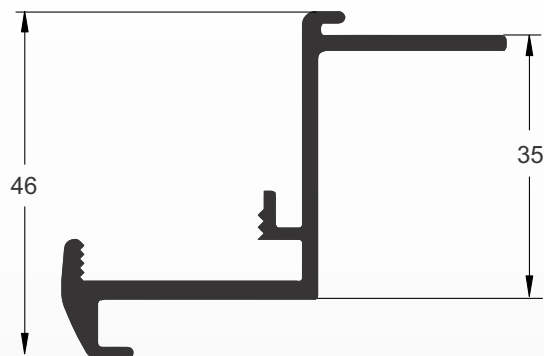

STL-0041

Merc.-----

Peso 0,730 kg/m

Descr.-----

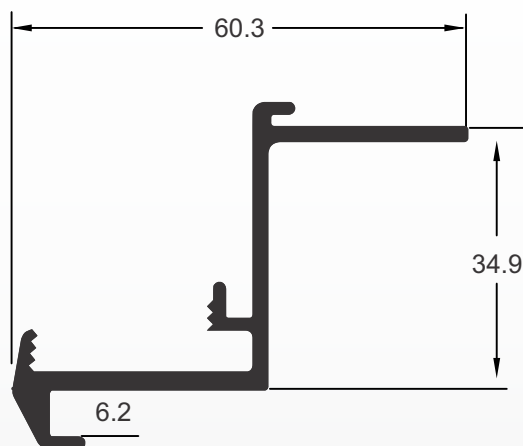

STL-1320

Merc. -----

Peso 0,917 kg/m

Descr. -----

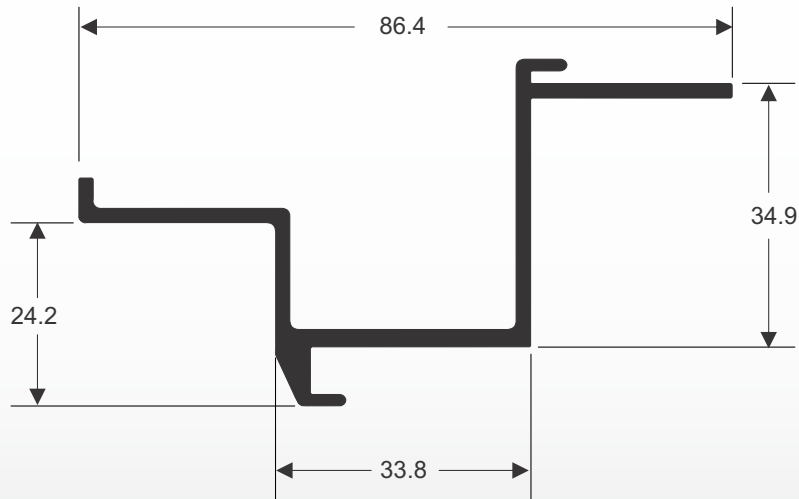

STL-1319

Merc. -----

Peso 0,903 kg/m

Descr. -----

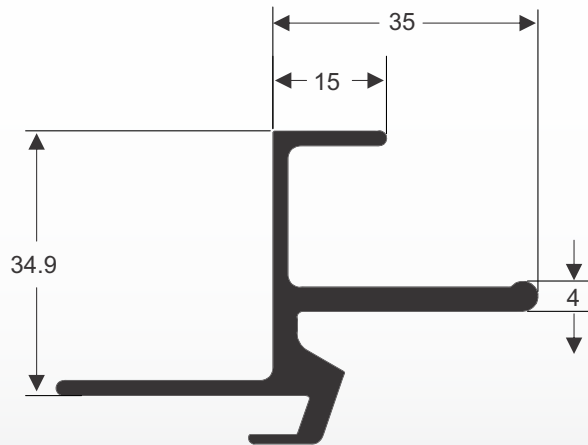

STL-0661

Merc. -----

Peso 0,883 kg/m

Descr. -----

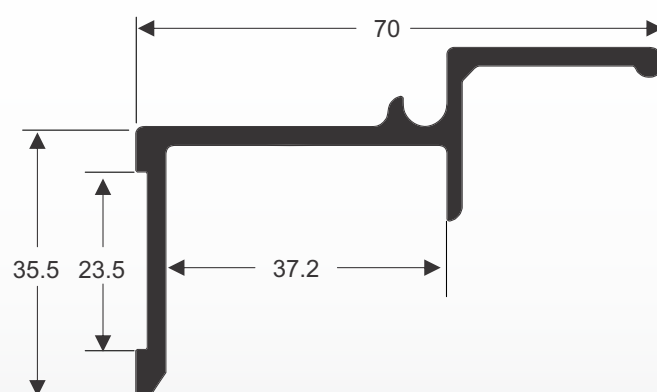

STL-1143

Merc. -----

Peso 0,474 kg/m

Descr. -----

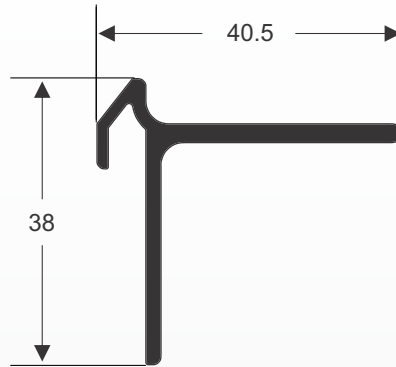

STL-0969

Merc. -----

Peso 0,617 kg/m

Descr. -----

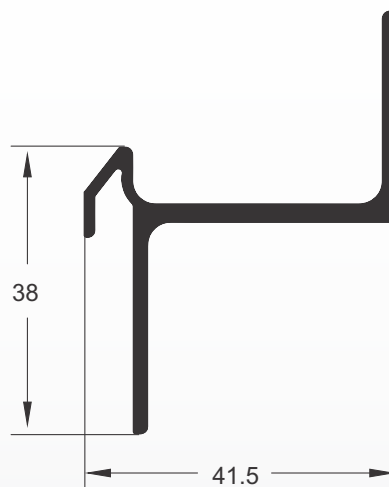

STL-0674

Merc. -----

Peso 0,159 kg/m

Descr. -----

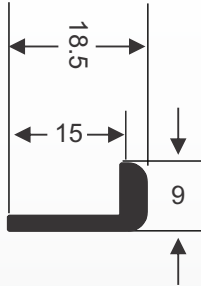

STL-1322

Merc. -----

Peso 0,120 kg/m

Descr. -----

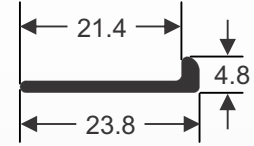

STL-0898

Merc. -----

Peso 0,149 kg/m

Descr. -----

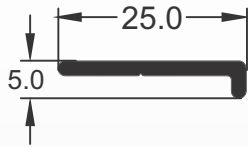

STL-1254

Merc. -----

Peso 0,726 kg/m

Descr. -----

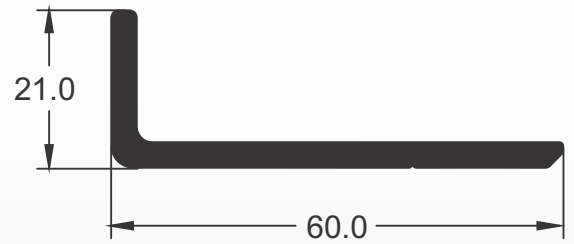

STL-1030

Merc. -----

Peso 0,154 kg/m

Descr. -----

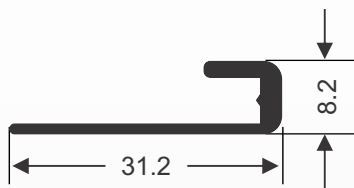

STL-0045

Merc. -----

Peso 0,126 kg/m

Descr. -----



STL-0684

Merc. -----

Peso 0,477 kg/m

Descr. -----

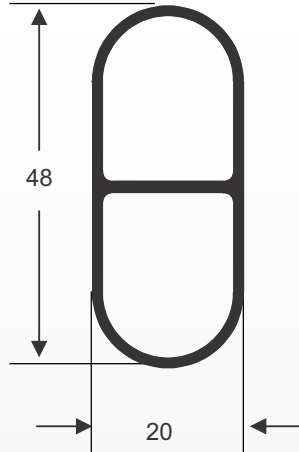

STL-0455

Merc. -----

Peso 0,491 kg/m

Descr. -----

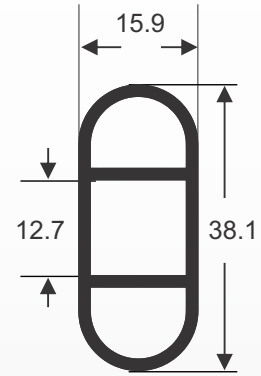

STL-1148

Merc. -----

Peso 0,626 kg/m

Descr. -----

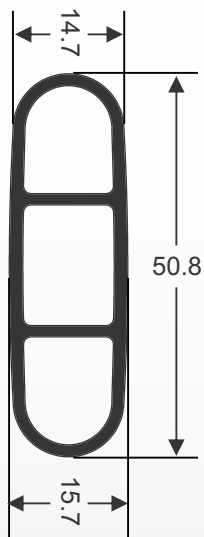

STL-0320

Merc. -----

Peso 0,471 kg/m

Descr. -----

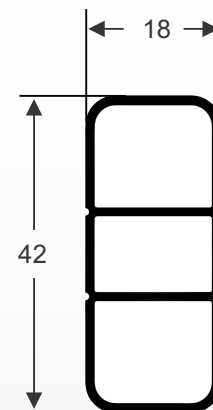

STL-1034

Merc. -----

Peso 0,974 kg/m

Descr. -----

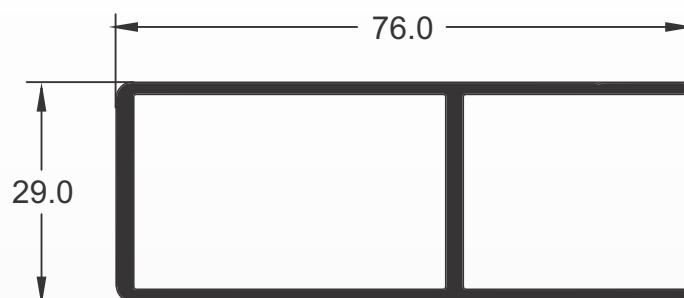

STL-1050

Merc. -----

Peso 1,149 kg/m

Descr. -----

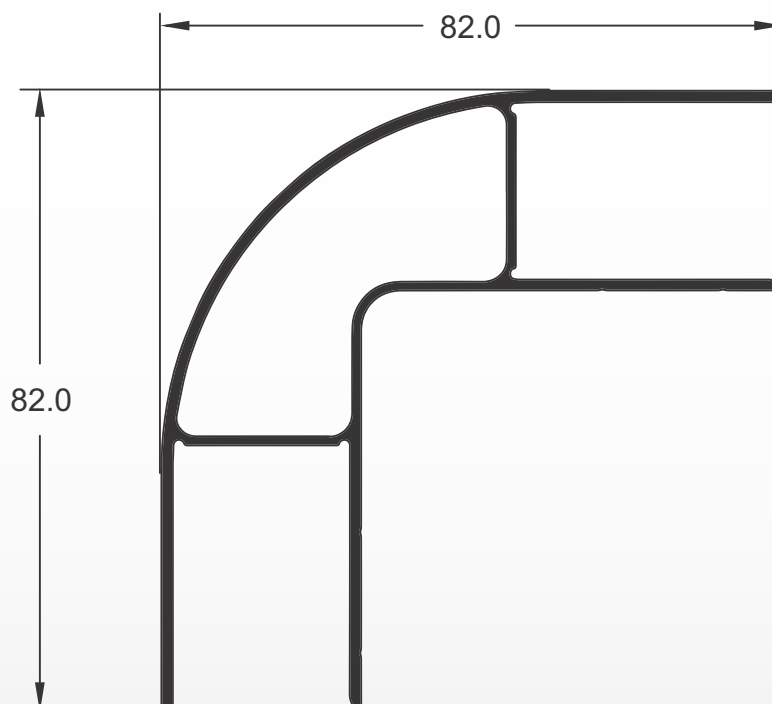

STL-1038

Merc. -----

Peso 1,694 kg/m

Descr. -----

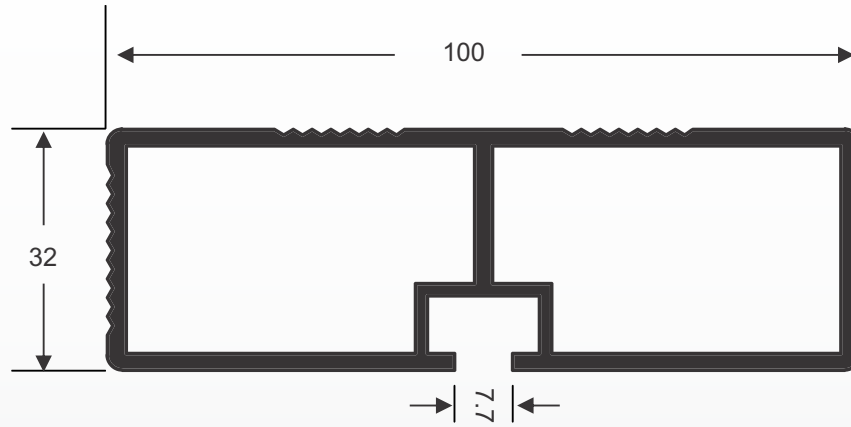

STL-1028

Merc. -----

Peso 1,550 kg/m

Descr. -----

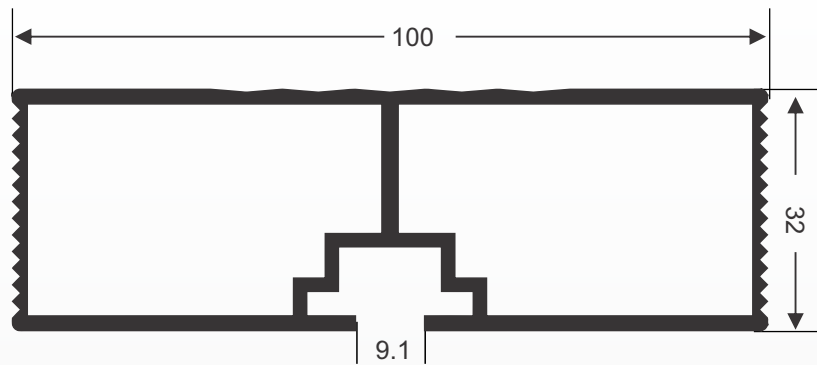

STL-1032

Merc. -----

Peso 1,807 kg/m

Descr. -----

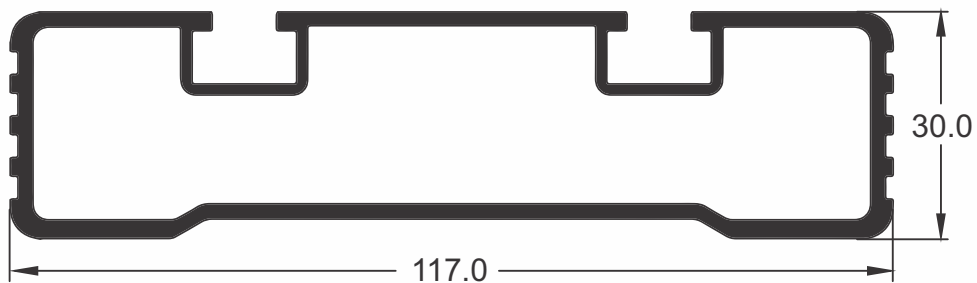

STL-0997

Merc. -----

Peso 1,094 kg/m

Descr. -----

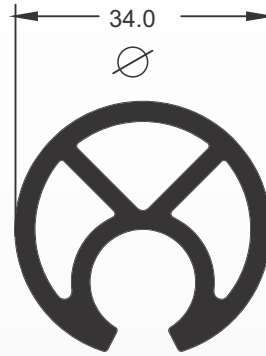

STL-1256

Merc. -----

Peso 1,208 kg/m

Descr. -----

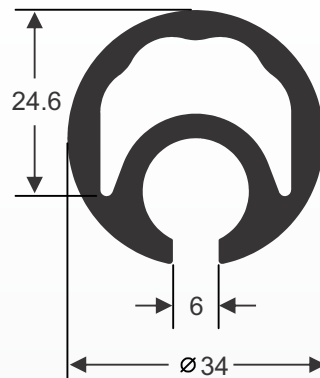

STL-0990

Merc. -----

Peso 2,171 kg/m

Descr. -----

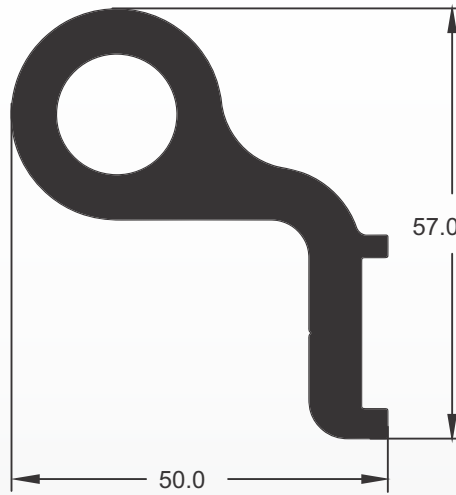

STL-1056

Merc. -----

Peso 1,741 kg/m

Descr. -----

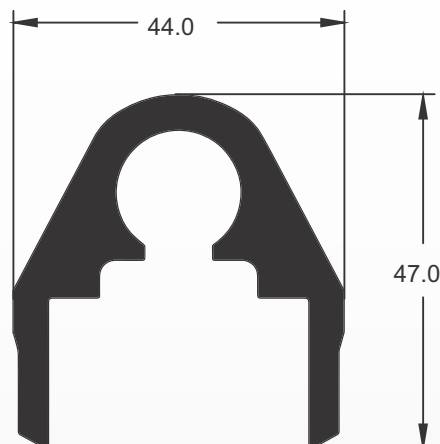

STL-1040

Merc. -----

Peso **4,675** kg/m

Descr. -----

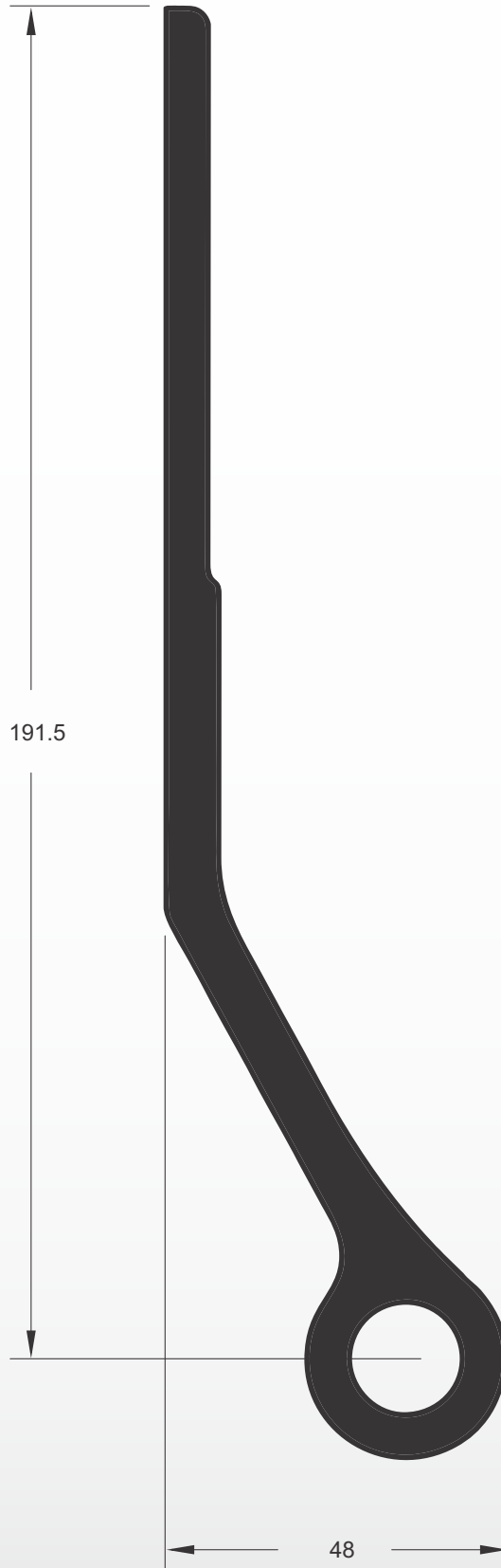

STL-1201

Merc. -----

Peso 0,609 kg/m

Descr. -----

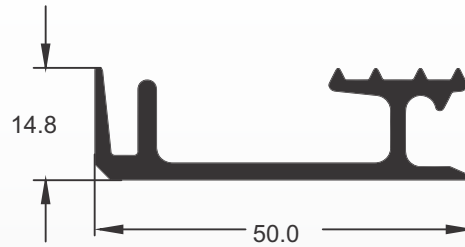

STL-1202

Merc. -----

Peso 0,787 kg/m

Descr. -----

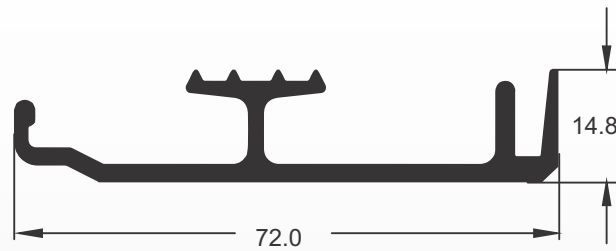

STL-1206

Merc. -----

Peso 1,037 kg/m

Descr. -----

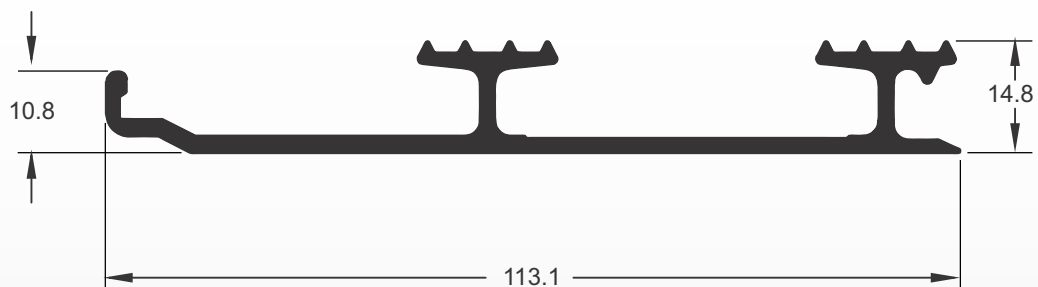

STL-1407

Merc. -----

Peso 2,100 kg/m

Descr. -----

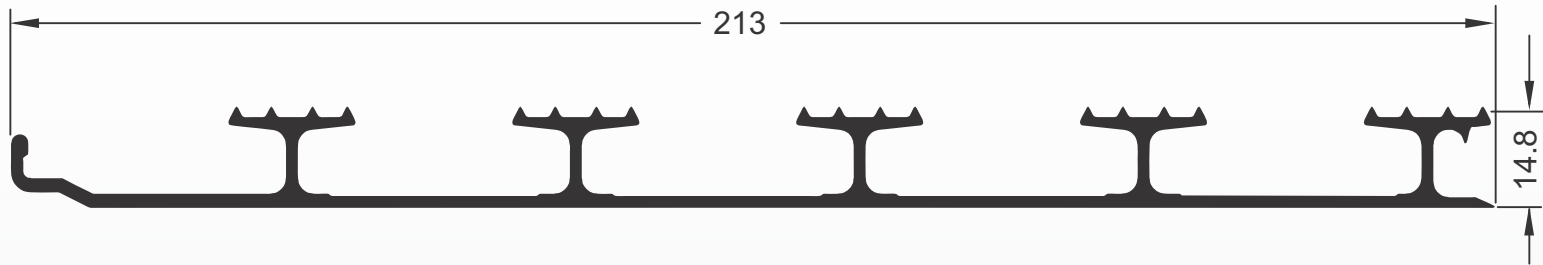

STL-0988

Merc. -----

Peso 4,286 kg/m

Descr. -----

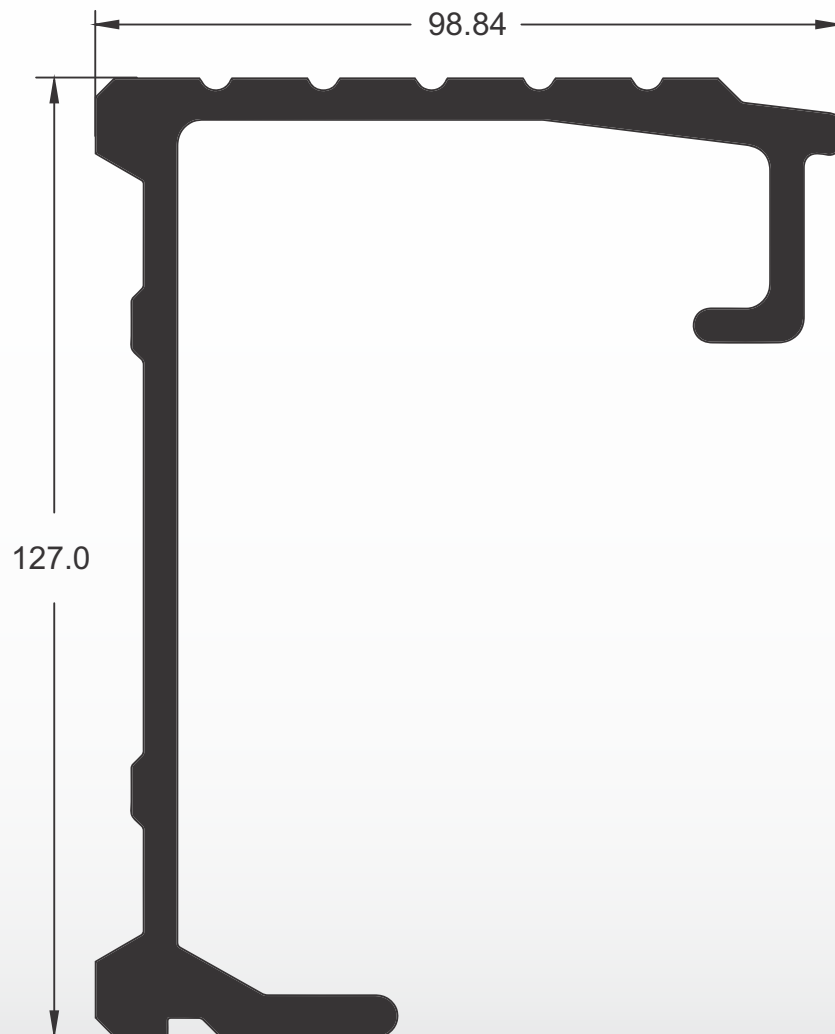

STL-0937

Merc. -----

Peso 2,684 kg/m

Descr. -----

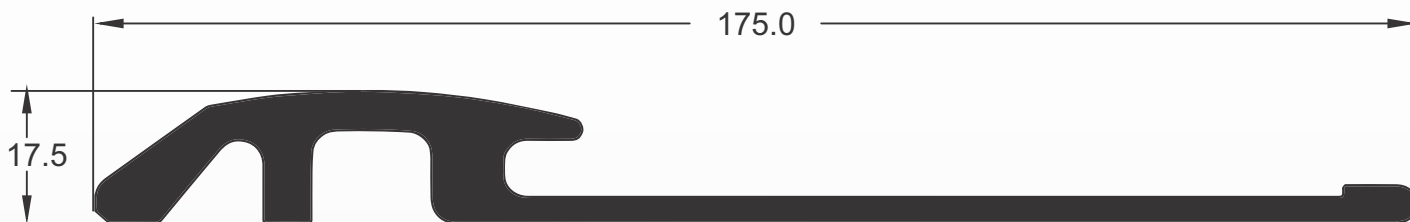

STL-1607

Merc. -----

Peso 3,156 kg/m

Descr. -----

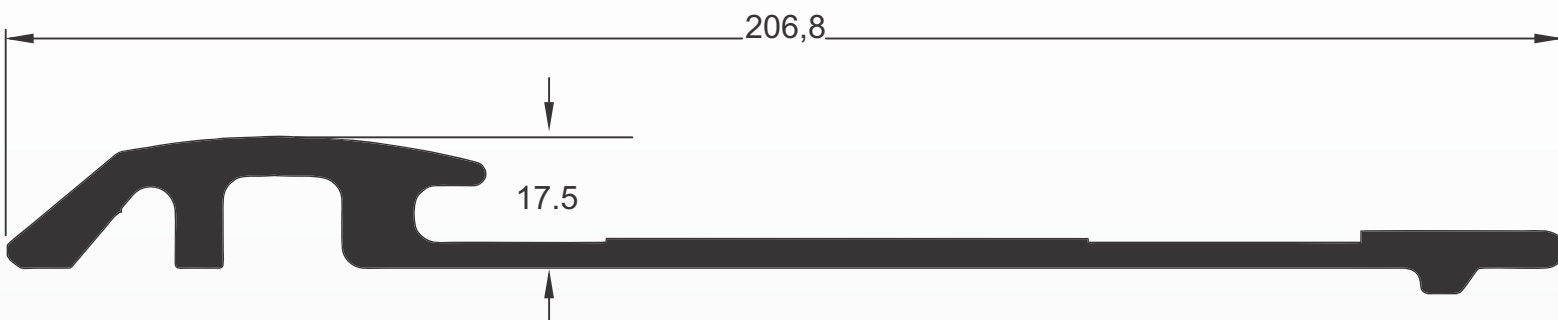

STL-0895

Merc. -----

Peso 1,855 kg/m

Descr. -----

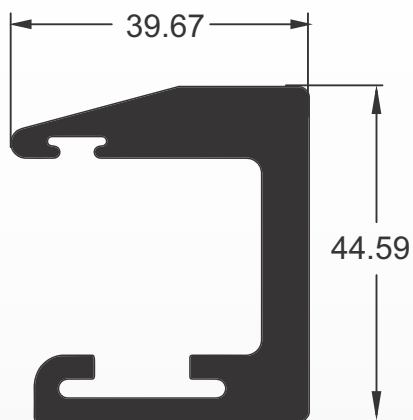

STL-0899

Merc. -----

Peso 3,144 kg/m

Descr. -----

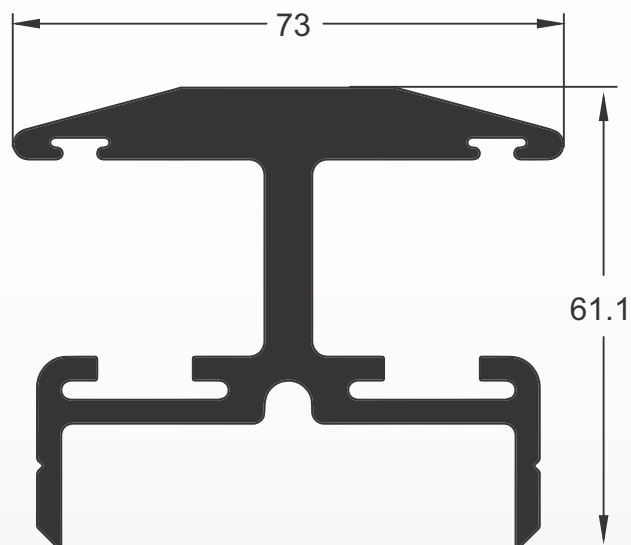

STL-0673

Merc. -----

Peso 1,158 kg/m

Descr. -----

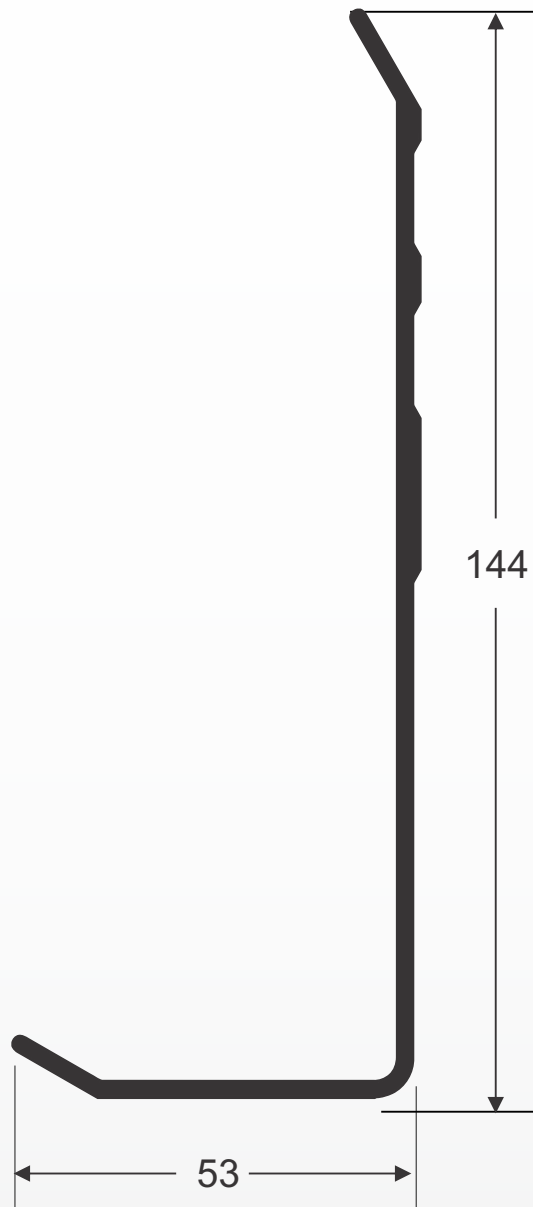

STL-0942

Merc. -----

Peso 1,076 kg/m

Descr. -----

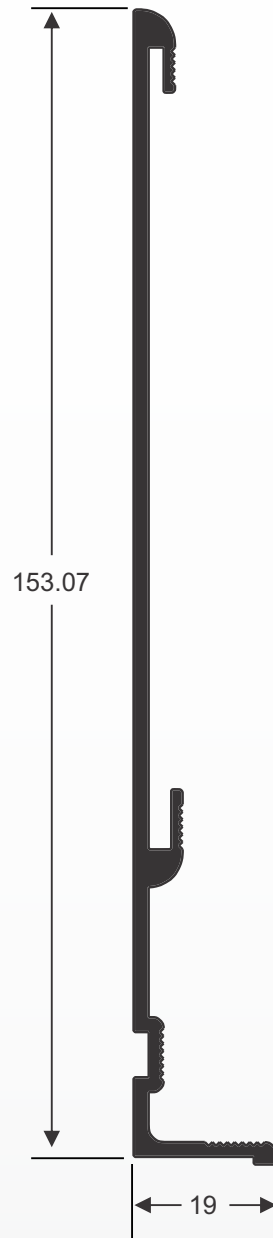

STL-0981

Merc. -----

Peso 0,203 kg/m

Descr. -----

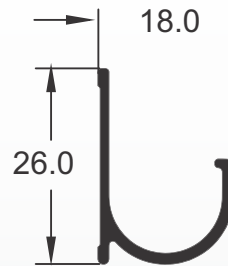

STL-0983

Merc. -----

Peso 0,694 kg/m

Descr. -----

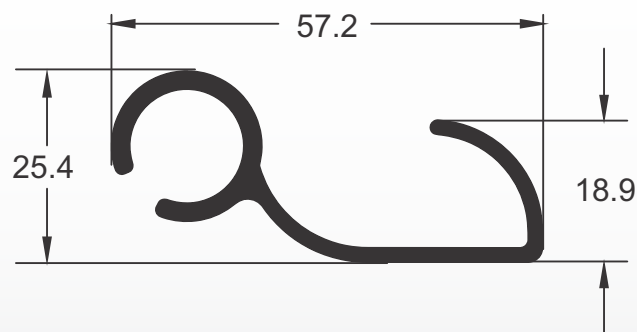

STL-0321

Merc. -----

Peso 0,882 kg/m

Descr. -----

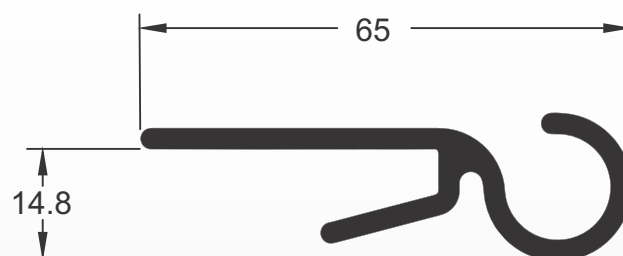

STL-0896

Merc. -----

Peso 0,540 kg/m

Descr. -----



STL-1838

Merc. -----

Peso 0,689 kg/m

Descr. -----



STL-0977

Merc. -----

Peso 0,970 kg/m

Descr. -----

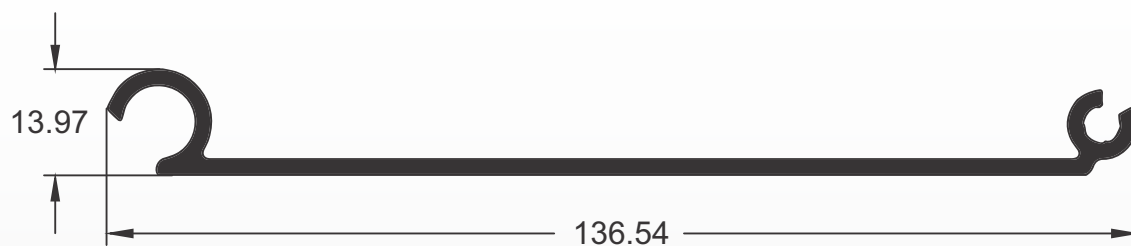

STL-0902

Merc. -----

Peso 1,248 kg/m

Descr. -----



STL-1807

Merc.-----

Peso 0,970 kg/m

Descr.-----

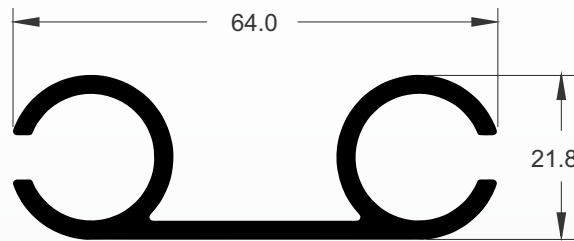

STL-1764

Merc.-----

Peso 1,404 kg/m

Descr.-----



STL-1027

Merc. -----

Peso 0,535 kg/m

Descr. -----

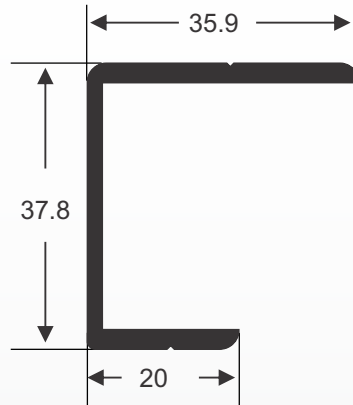

STL-1203

Merc. -----

Peso 2,070 kg/m

Descr. -----

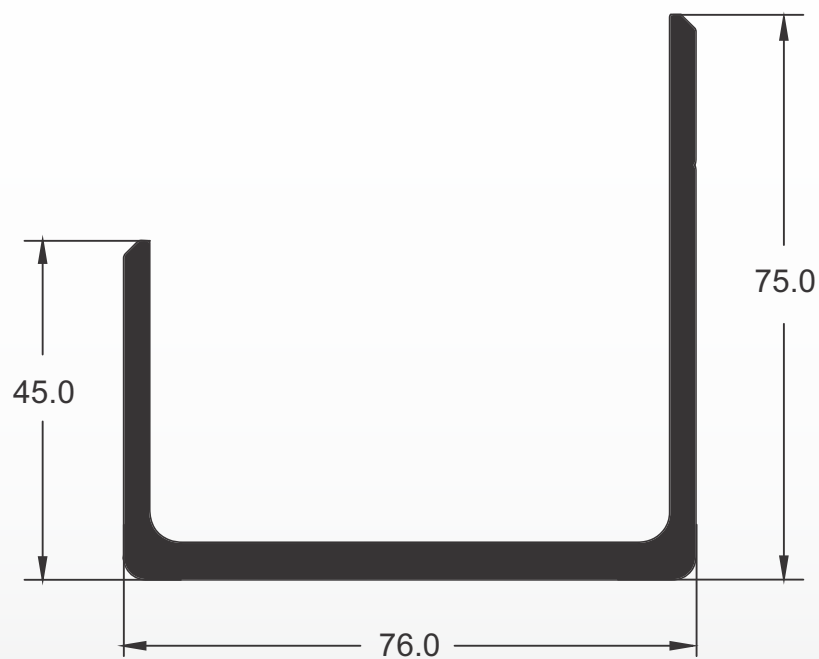

STL-1070

Merc. -----

Peso 2,120 kg/m

Descr. -----

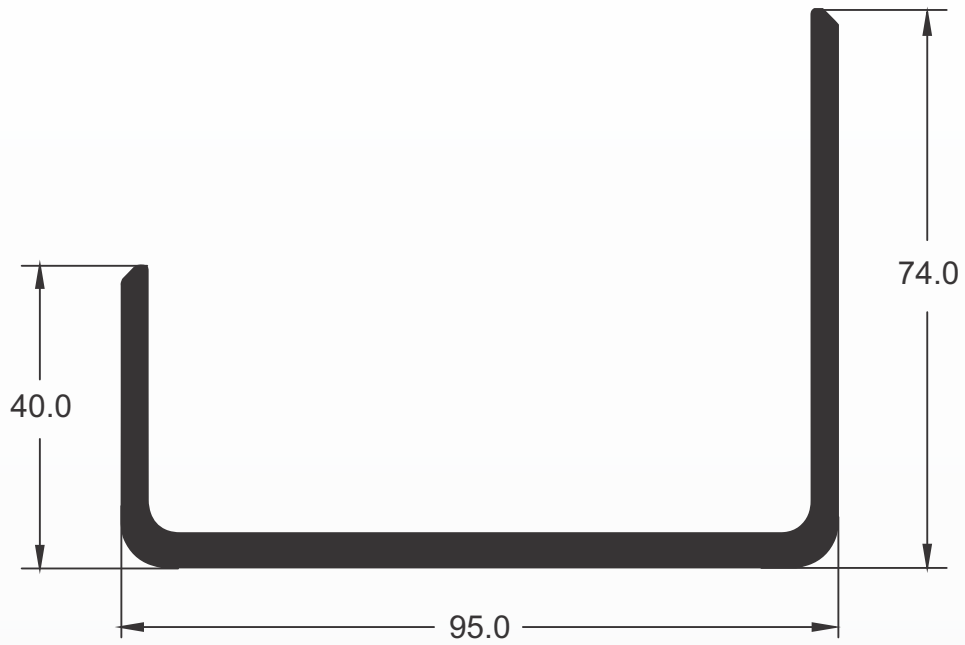

STL-0933

Merc. -----

Peso 0,928 kg/m

Descr. -----

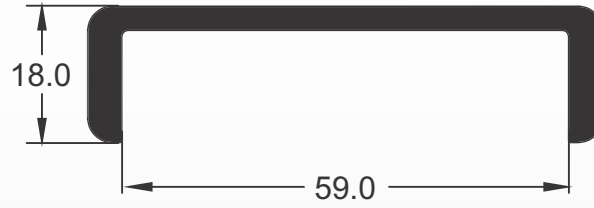

STL-1054

Merc. -----

Peso 2,608 kg/m

Descr. -----

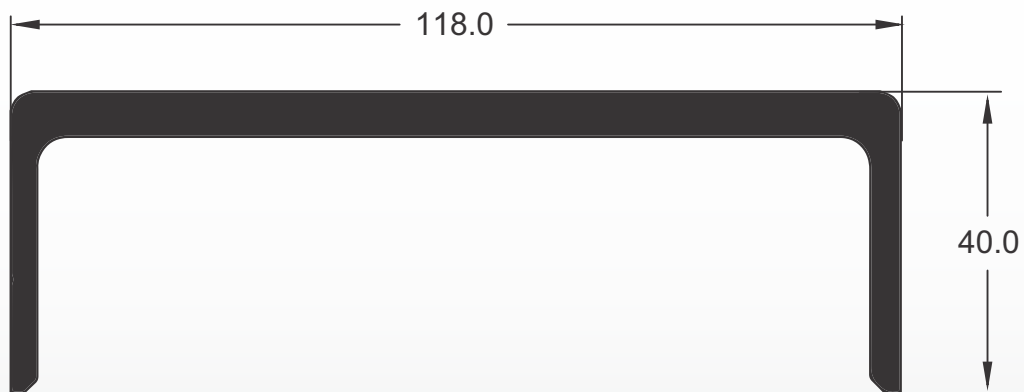

STL-0934

Merc. -----

Peso 1,300 kg/m

Descr. -----

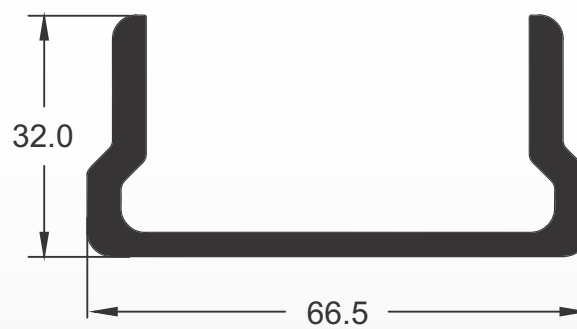

STL-0935

Merc.-----

Peso 0,764 kg/m

Descr.-----

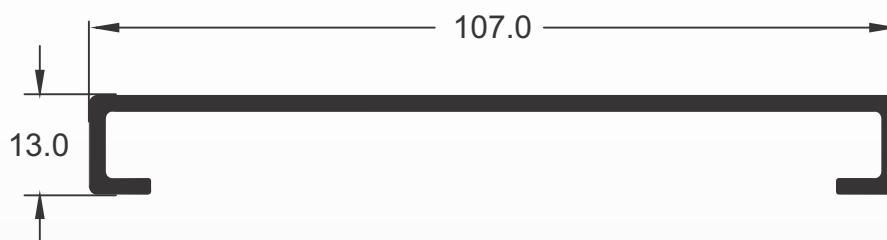

STL-1061

Merc.-----

Peso 3,848 kg/m

Descr.-----



STL-0932

Merc. -----

Peso 1,769 kg/m

Descr. -----



STL-1702

Merc. -----

Peso 0,788 kg/m

Descr. -----

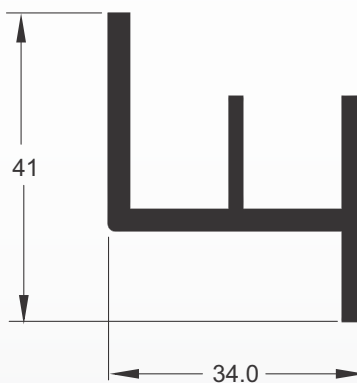

STL-1060

Merc. -----

Peso 1,550 kg/m

Descr. -----

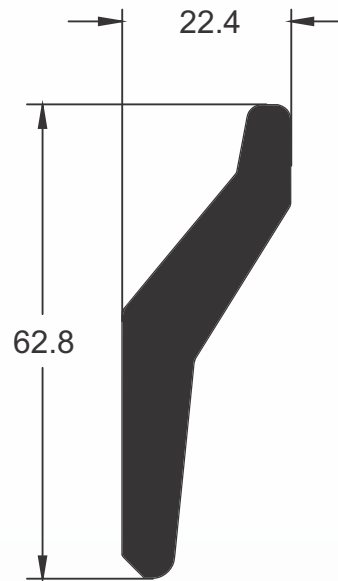

STL-1039

Merc.-----

Peso 2,432 kg/m

Descr.-----

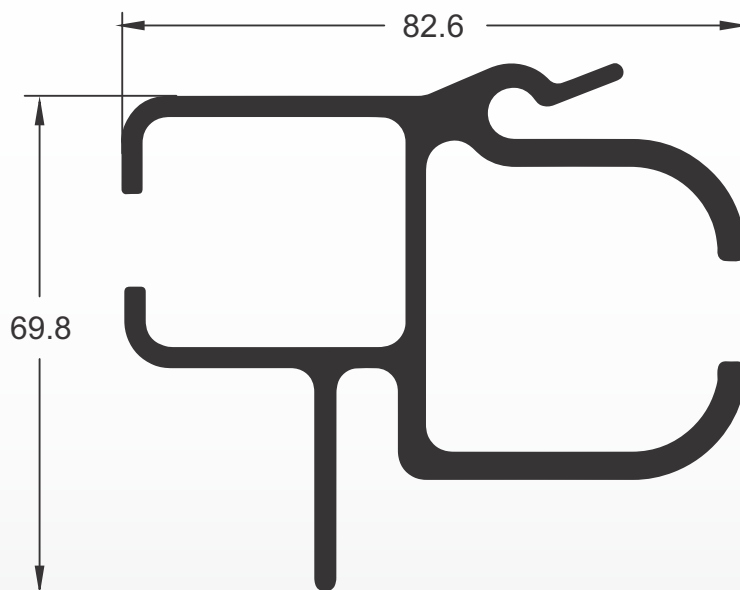

STL-0897

Merc.-----

Peso 3,388 kg/m

Descr.-----

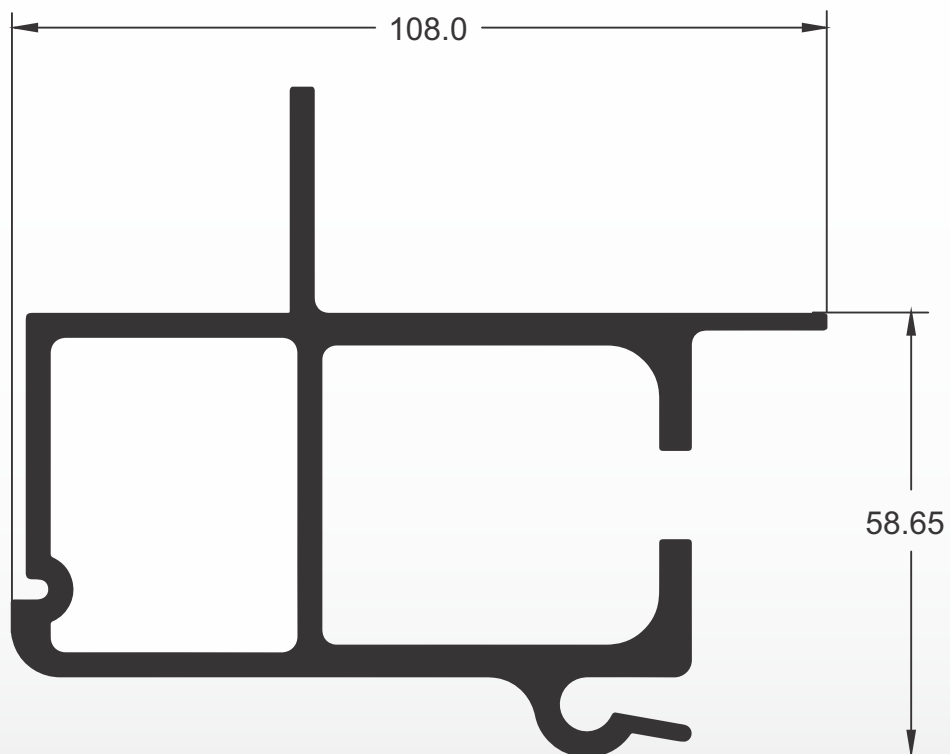

STL-0373

Merc. -----

Peso 0,730 kg/m

Descr. -----

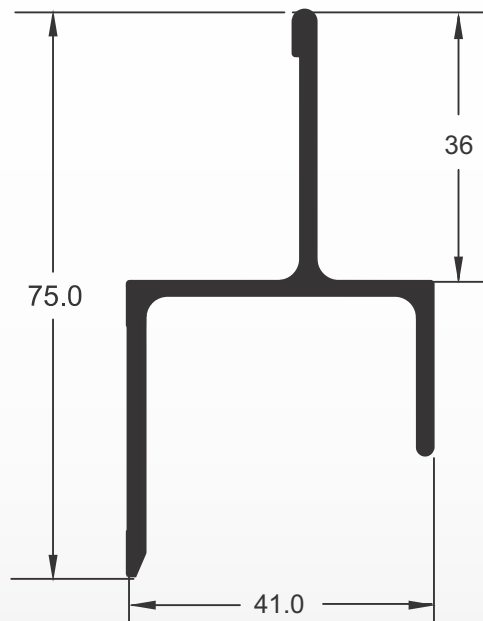

STL-0374

Merc. -----

Peso 0,562 kg/m

Descr. -----

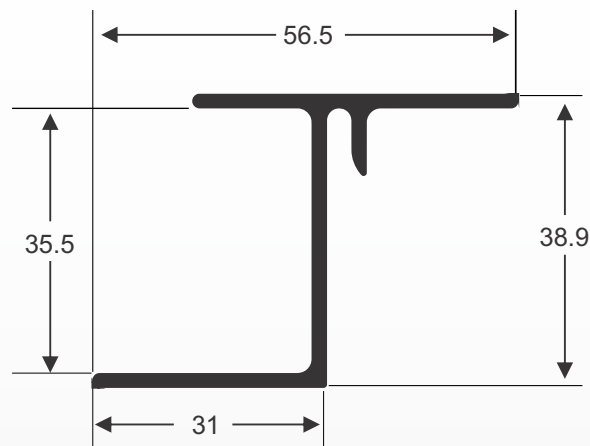

STL-0733

Merc. -----

Peso 0,889 kg/m

Descr. -----

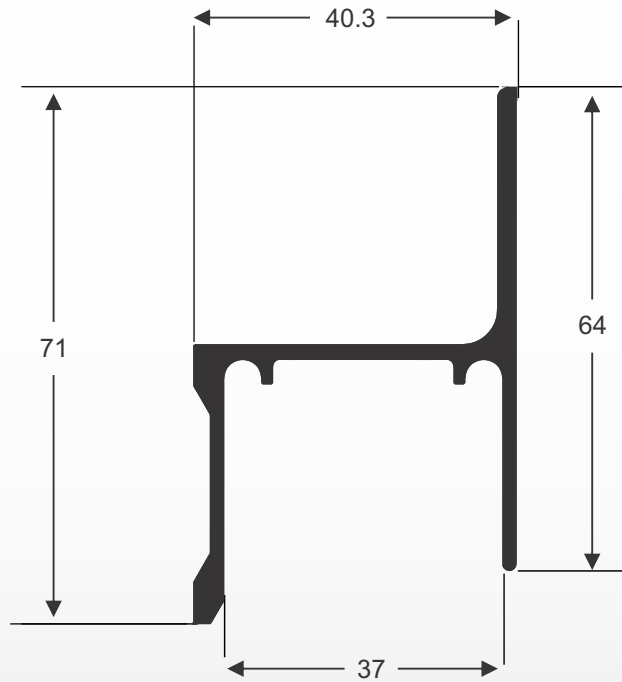

STL-0039

Merc. -----

Peso 1,151 kg/m

Descr. -----

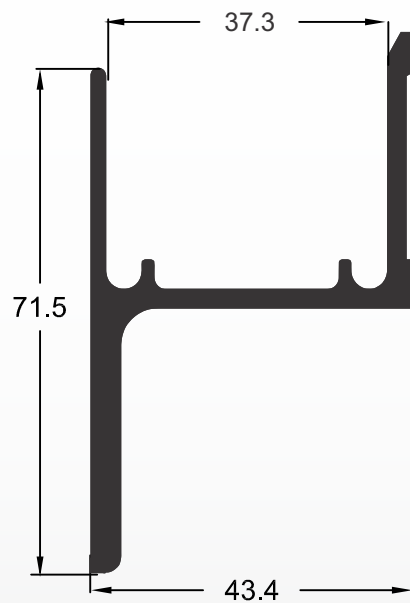

STL-0982

Merc. -----

Peso 0,997 kg/m

Descr. -----

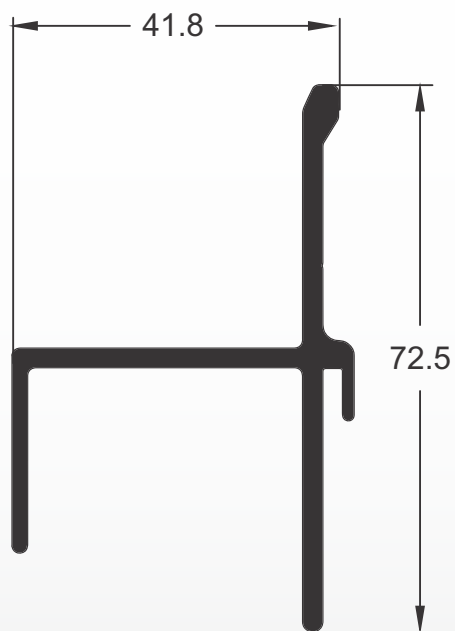

STL-0668

Merc. -----

Peso 1,020 kg/m

Descr. -----

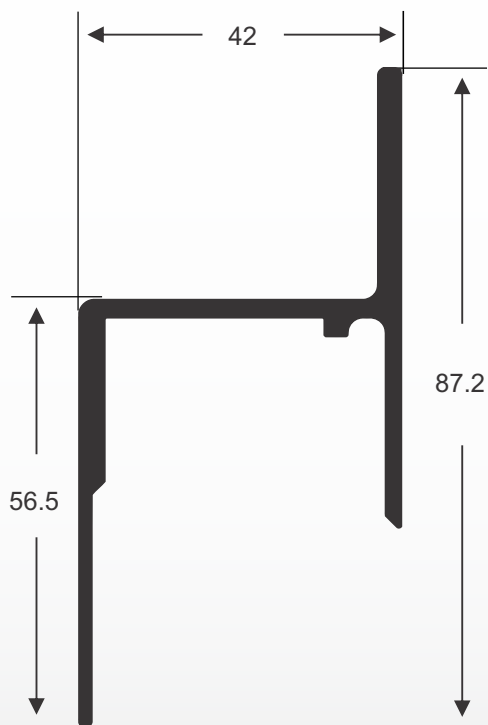

STL-0040

Merc. -----

Peso 0,940 kg/m

Descr. -----

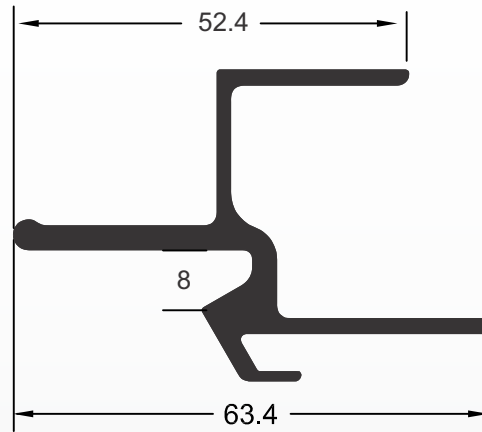

STL-0393

Merc. -----

Peso 0,970 kg/m

Descr. -----

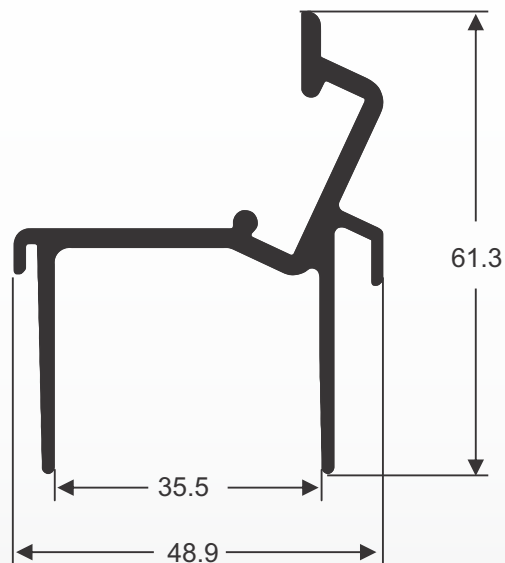

STL-0392

Merc. -----

Peso 1,072 kg/m

Descr. -----

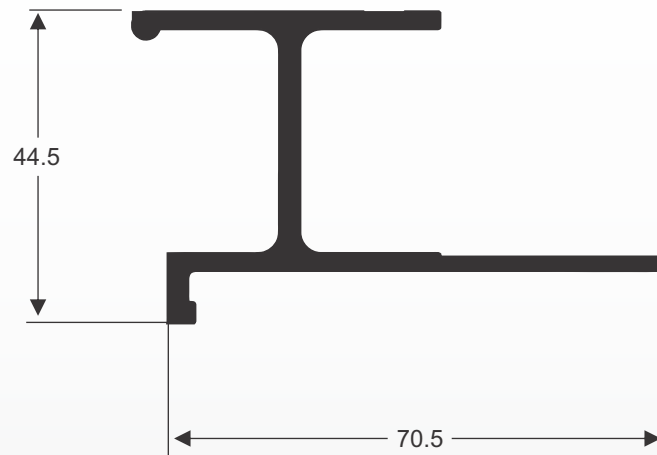

STL-0312

Merc. -----

Peso 0,595 kg/m

Descr. -----

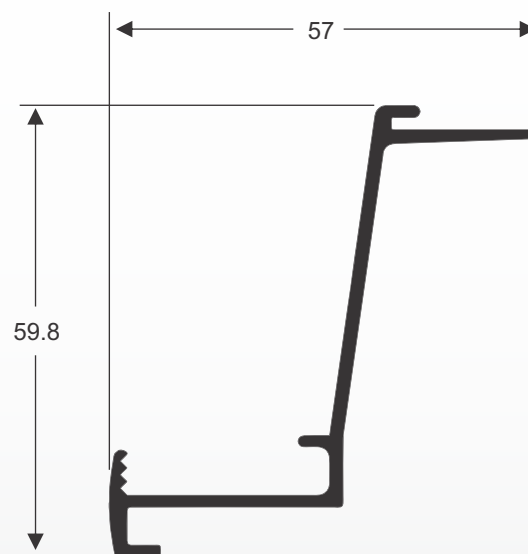

STL-1189

Merc. -----

Peso 1,030 kg/m

Descr. -----

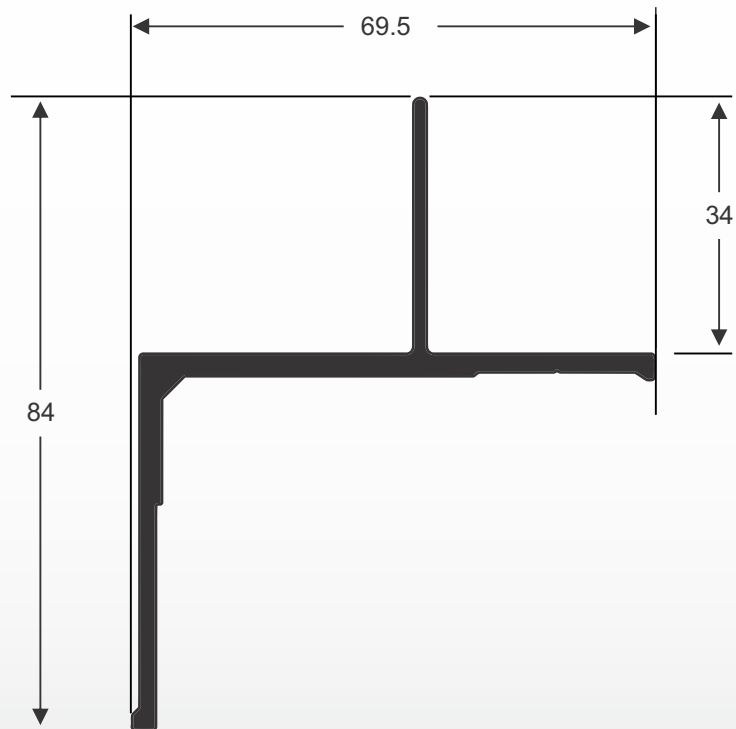

STL-0121

Merc. -----

Peso 0,884 kg/m

Descr. -----

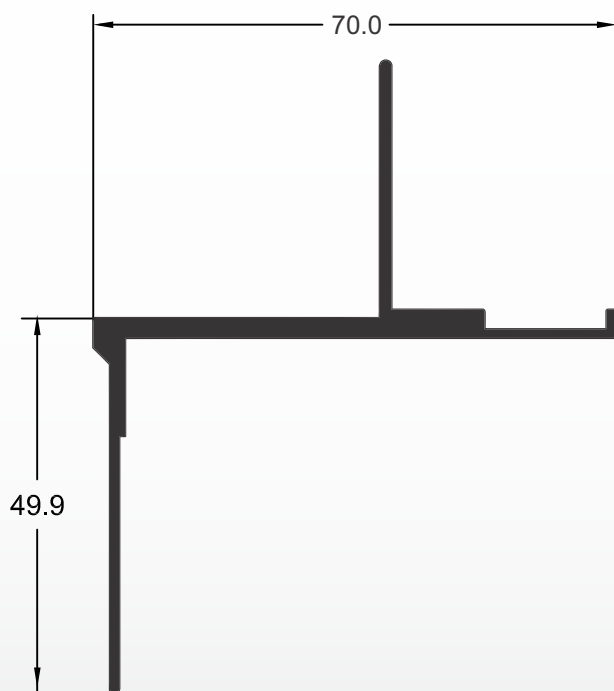

STL-0070

Merc. -----

Peso 0,526 kg/m

Descr. -----

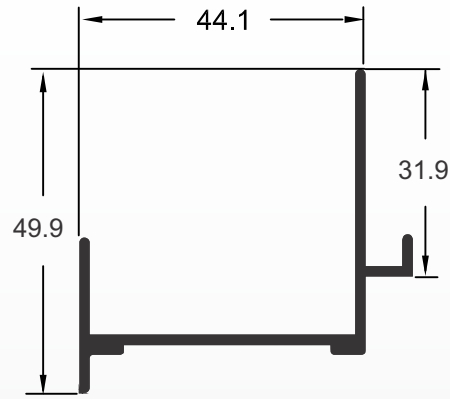

STL-0122

Merc. -----

Peso 0,538 kg/m

Descr. -----

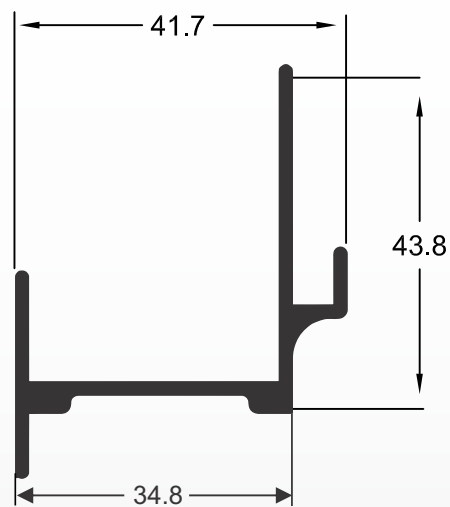

STL-1185

Merc. -----

Peso 0,428 kg/m

Descr. -----

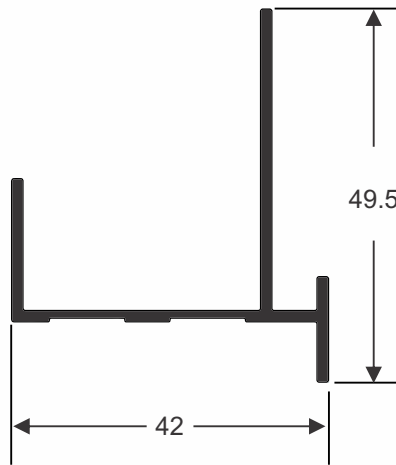

STL-0970

Merc.-----

Peso 0,615 kg/m

Descr.-----

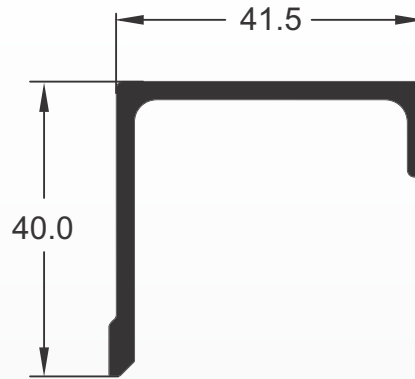

STL-1323

Merc.-----

Peso 0,665 kg/m

Descr.-----

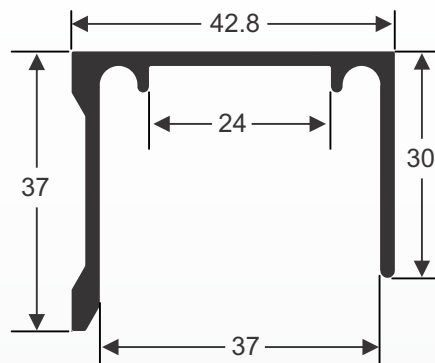

STL-1258

Merc. -----

Peso 1,528 kg/m

Descr. -----

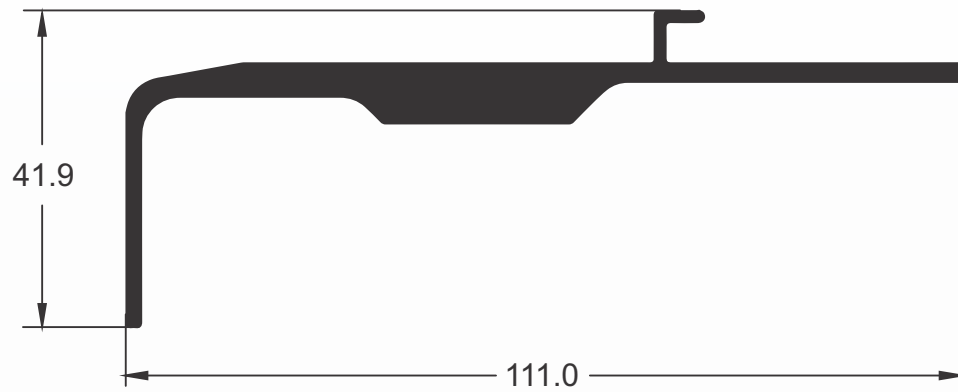

STL-0347

Merc. -----

Peso 2,186 kg/m

Descr. -----

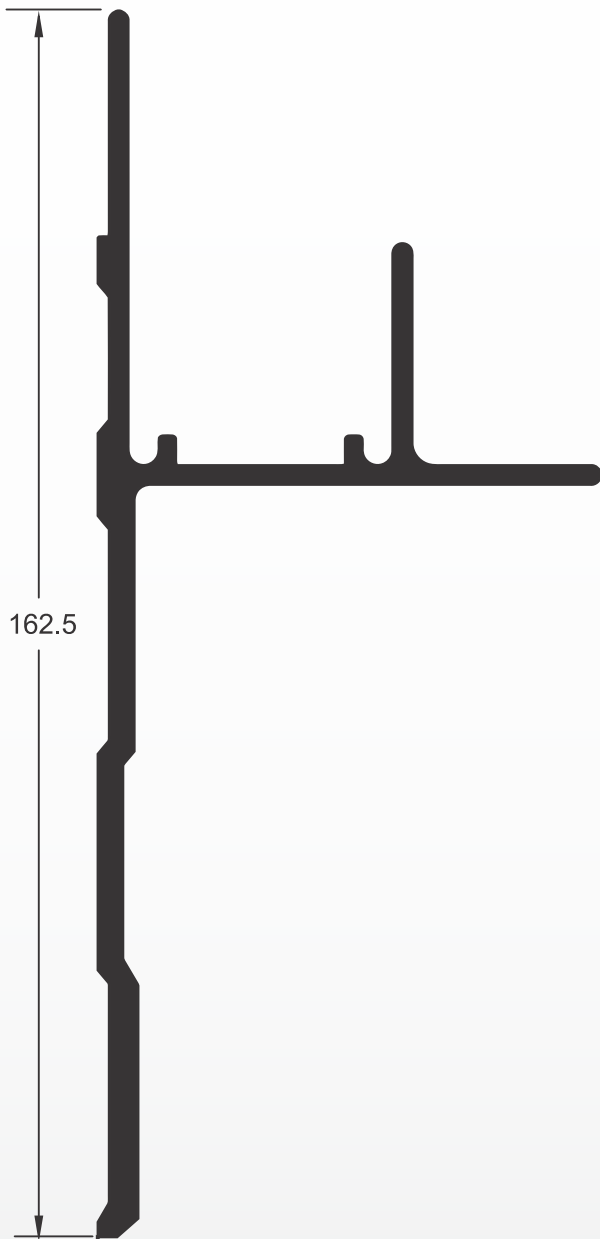

STL-0348

Merc. -----

Peso 2,601 kg/m

Descr. -----

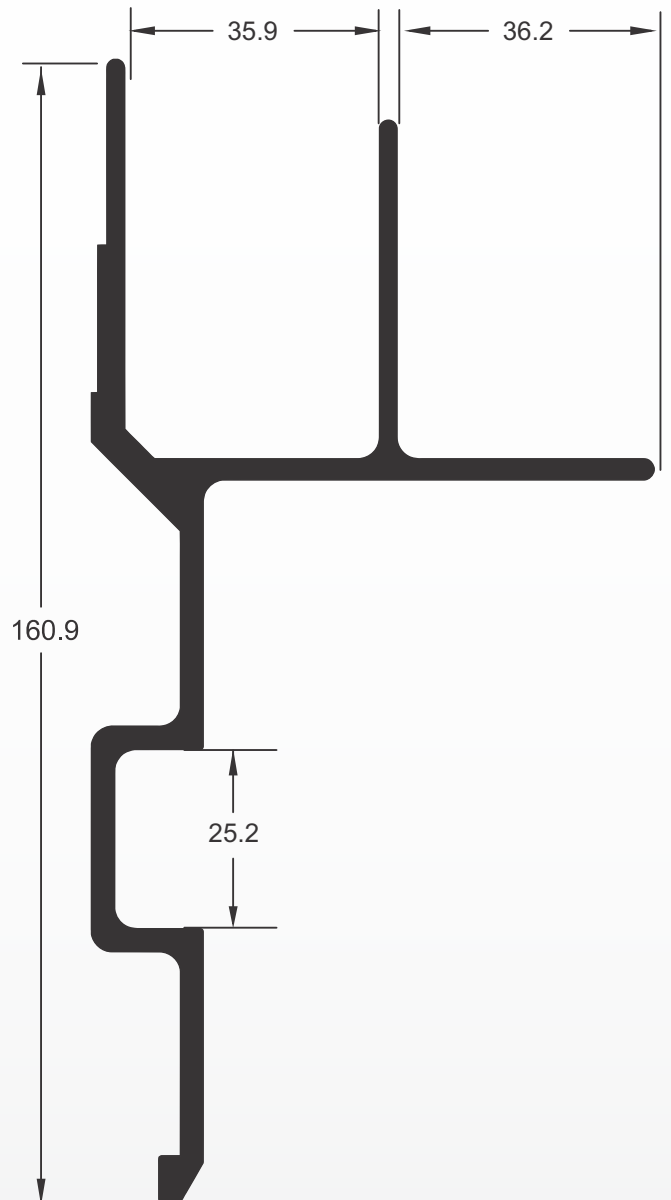

STL-0375

Merc. -----

Peso 1,357 kg/m

Descr. -----

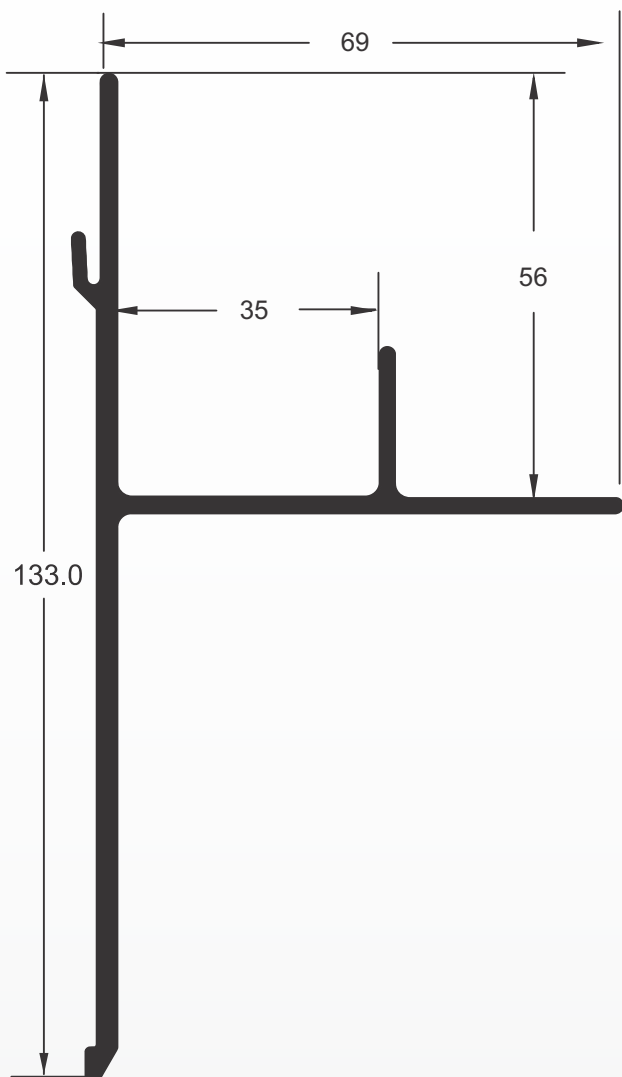

STL-0376

Merc. -----

Peso 0,967 kg/m

Descr. -----

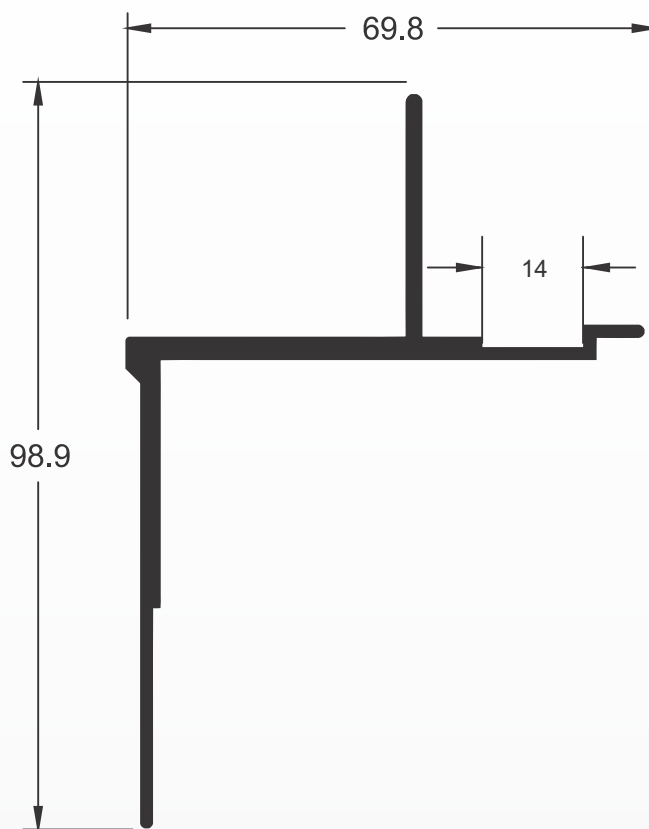

STL-0662

Merc. -----

Peso 1,173 kg/m

Descr. -----

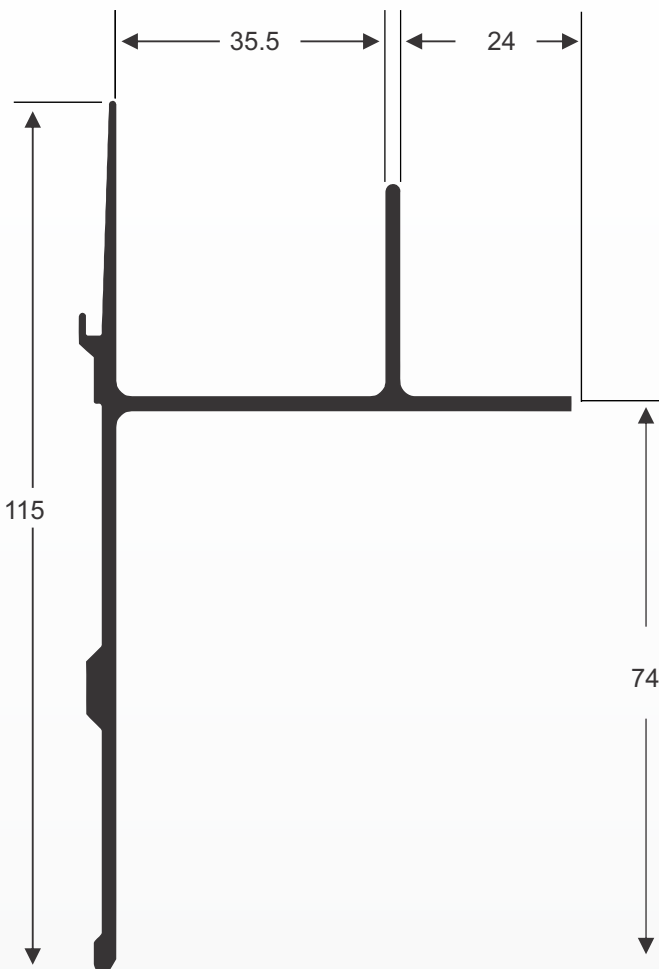

STL-1382

Merc. -----

Peso 2,466 kg/m

Descr. -----

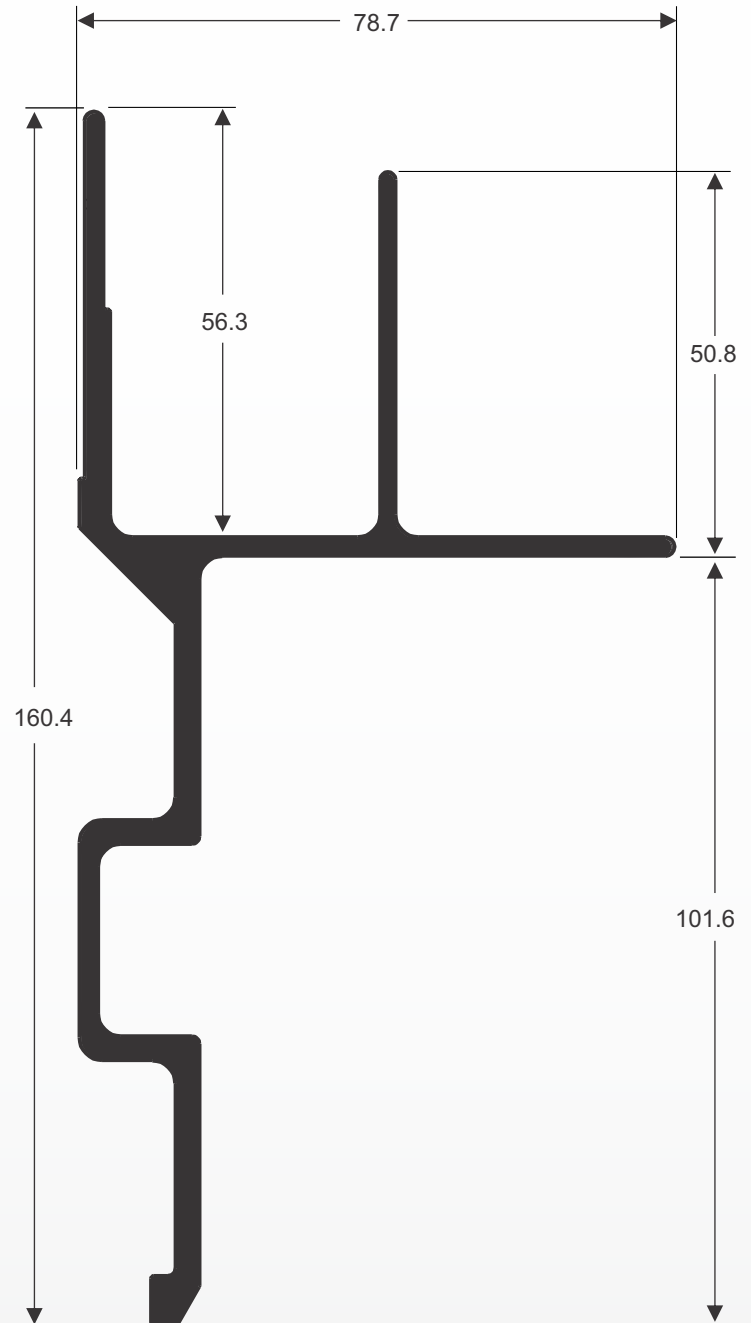

STL-0670

Merc. -----

Peso 1,726 kg/m

Descr. -----

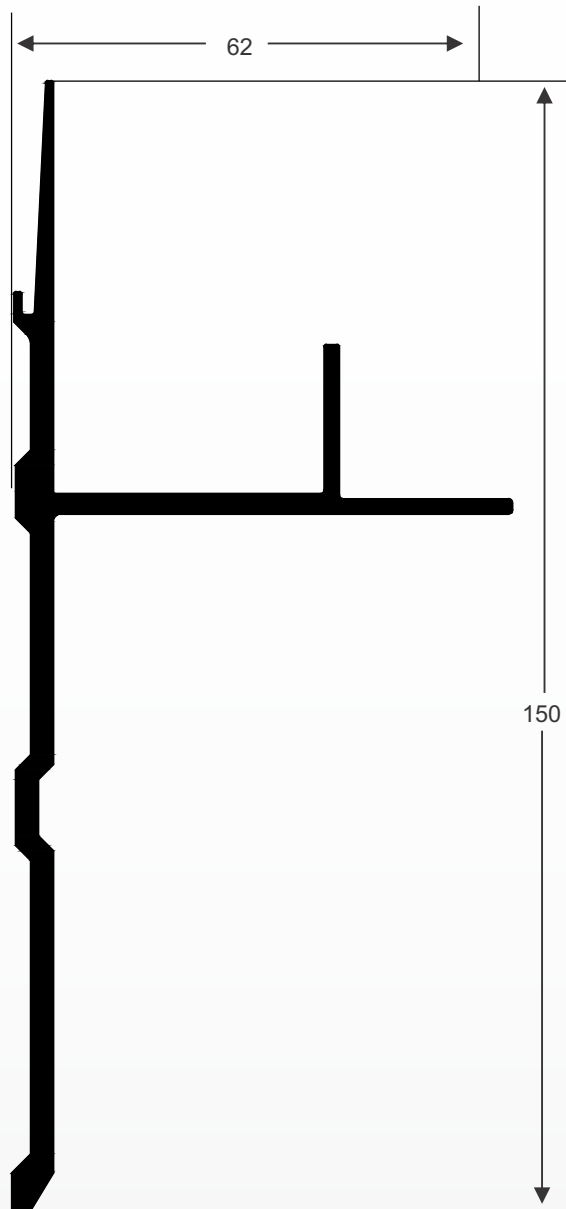

STL-0671

Merc. -----

Peso 1,937 kg/m

Descr. -----

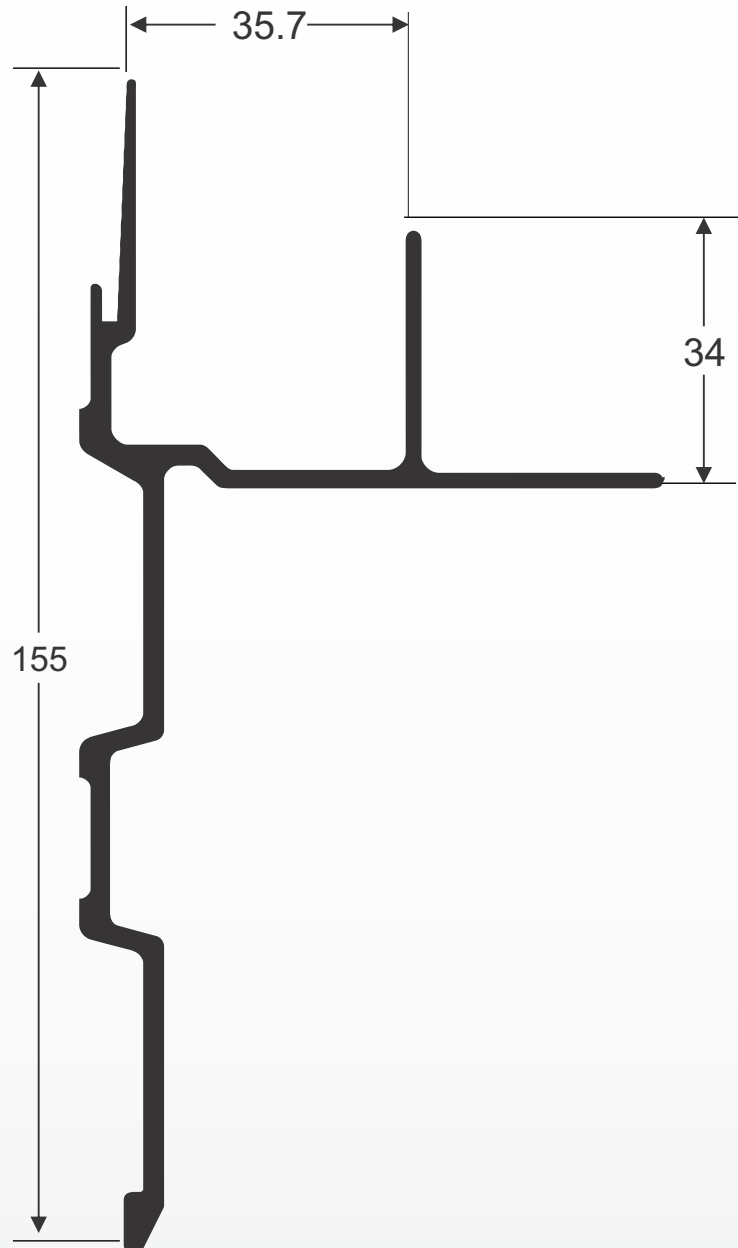

STL-0672

Merc. -----

Peso 2,165 kg/m

Descr. -----

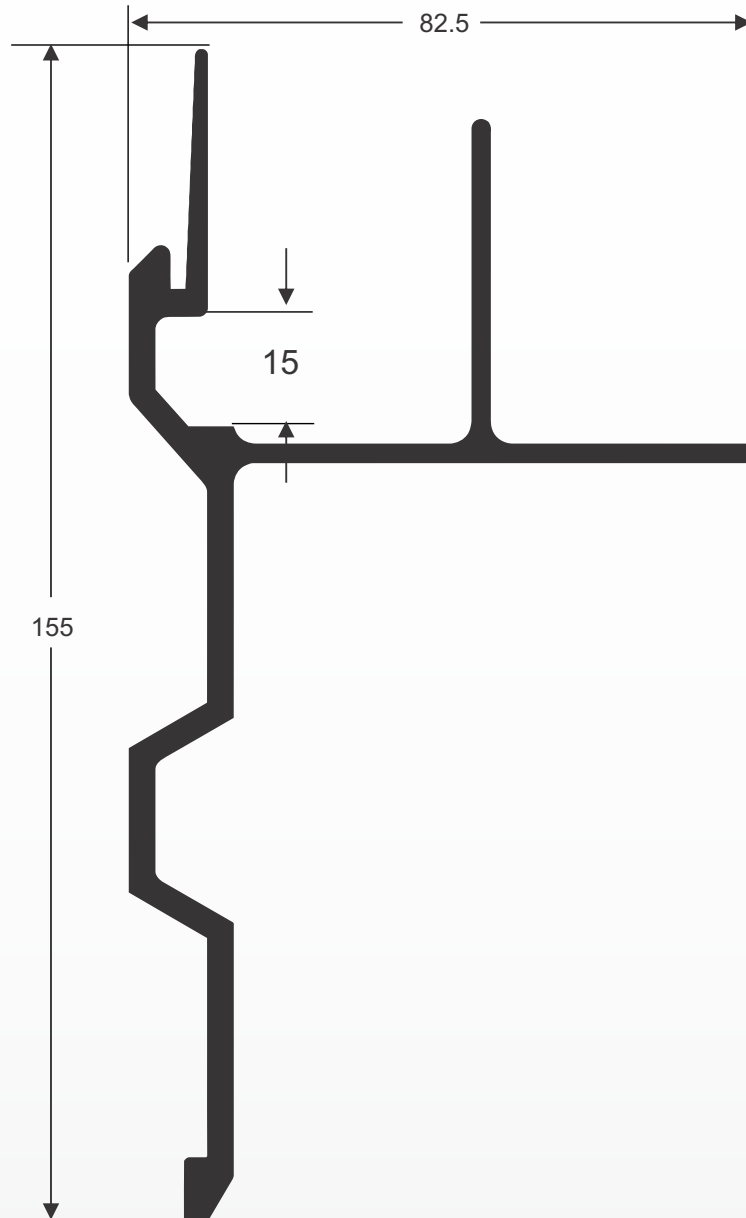

STL-0682

Merc. -----

Peso 1,639 kg/m

Descr. -----

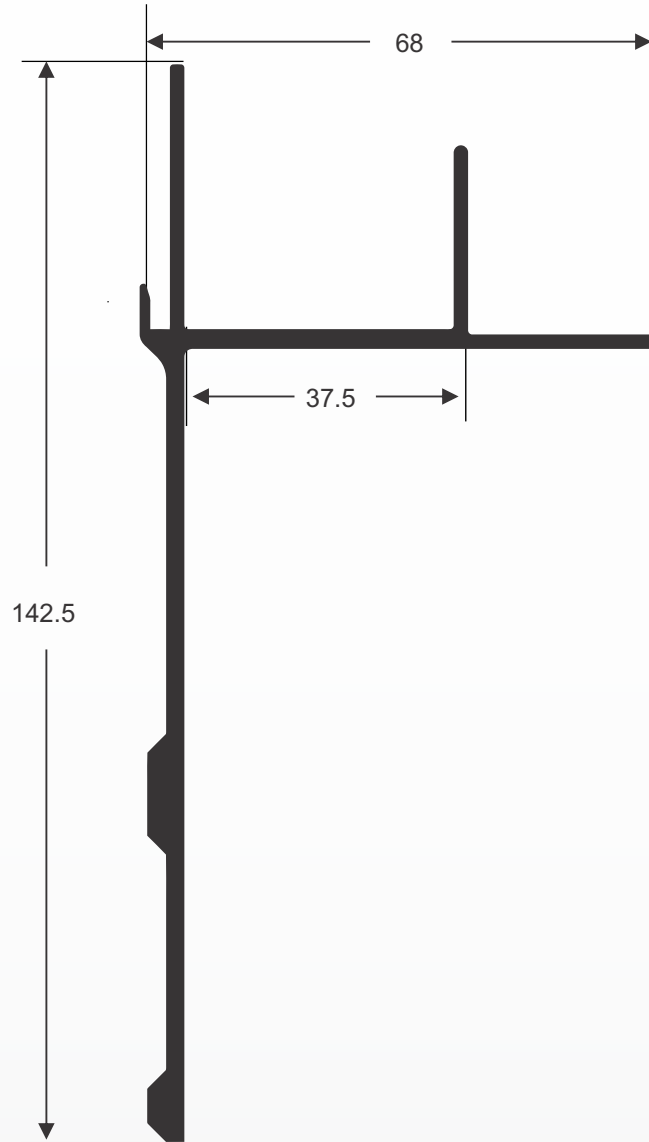

STL-0683

Merc. -----

Peso 1,366 kg/m

Descr. -----

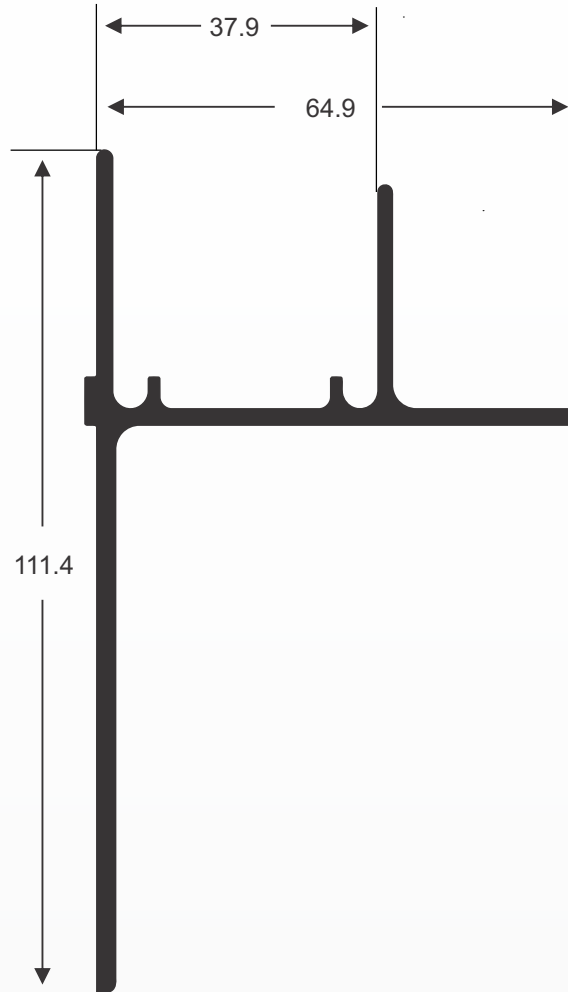

STL-0719

Merc. -----

Peso 1,974 kg/m

Descr. -----

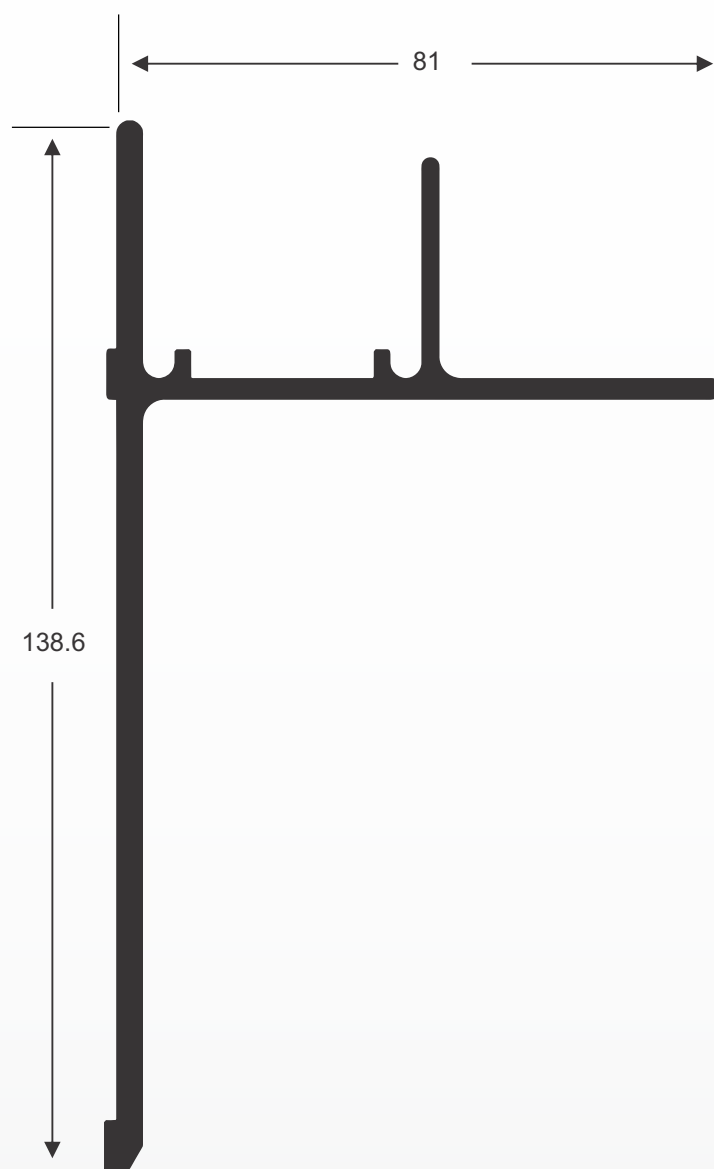

STL-0794

Merc. -----

Peso 1,334 kg/m

Descr. -----

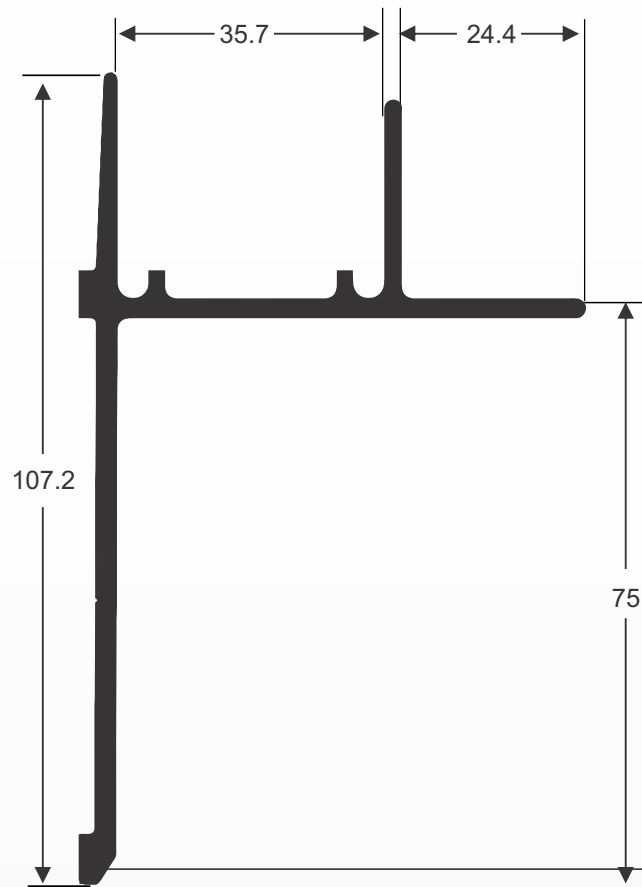

STL-0795

Merc. -----

Peso 1,868 kg/m

Descr. -----

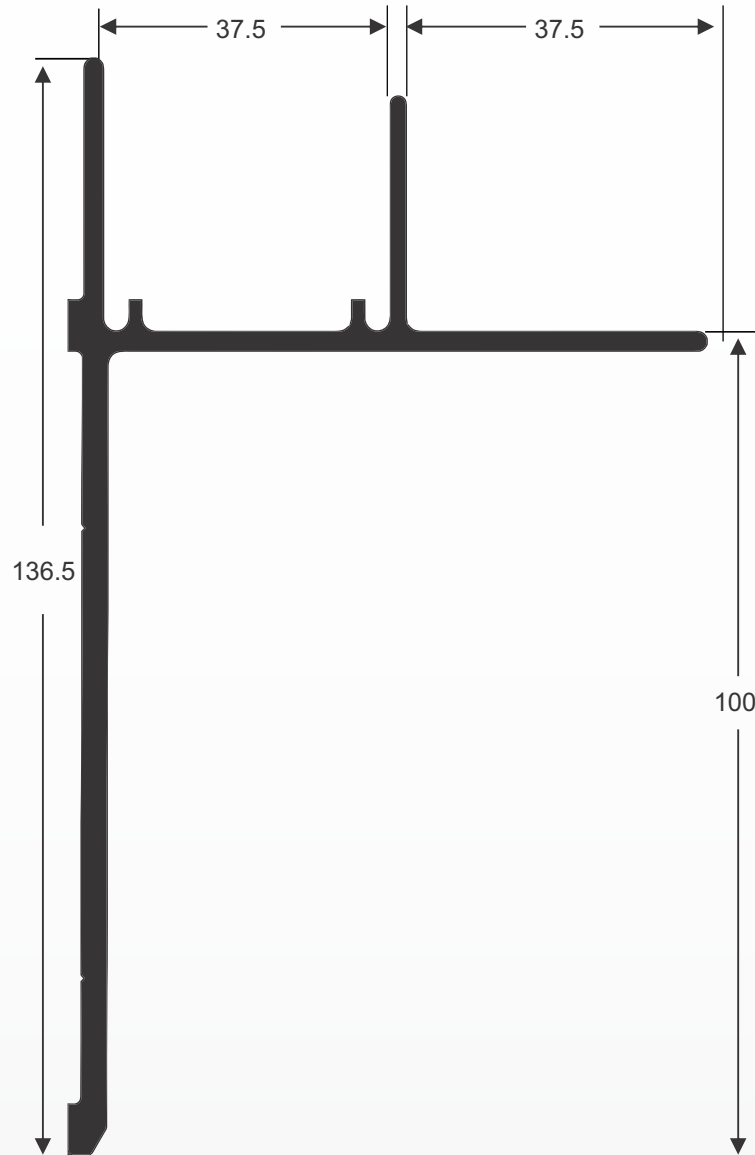

STL-0821

Merc. -----

Peso 2,339 kg/m

Descr. -----

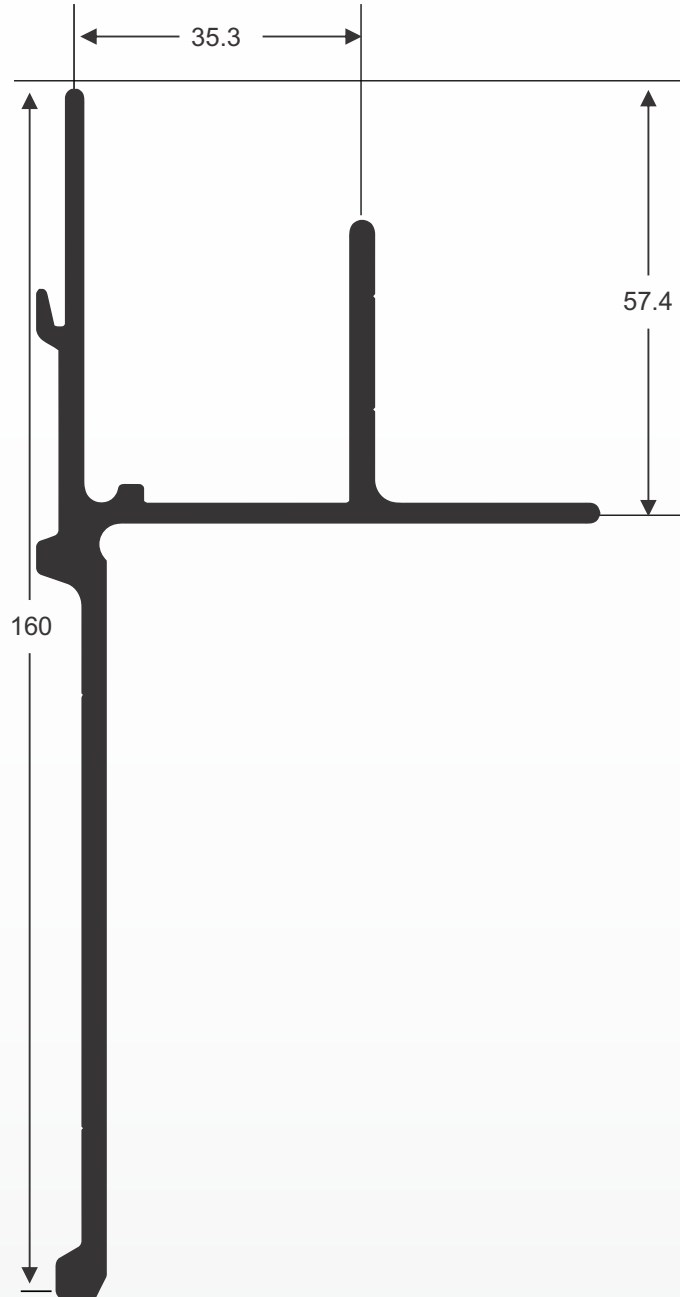

STL-0736

Merc. -----

Peso 1,805 kg/m

Descr. -----

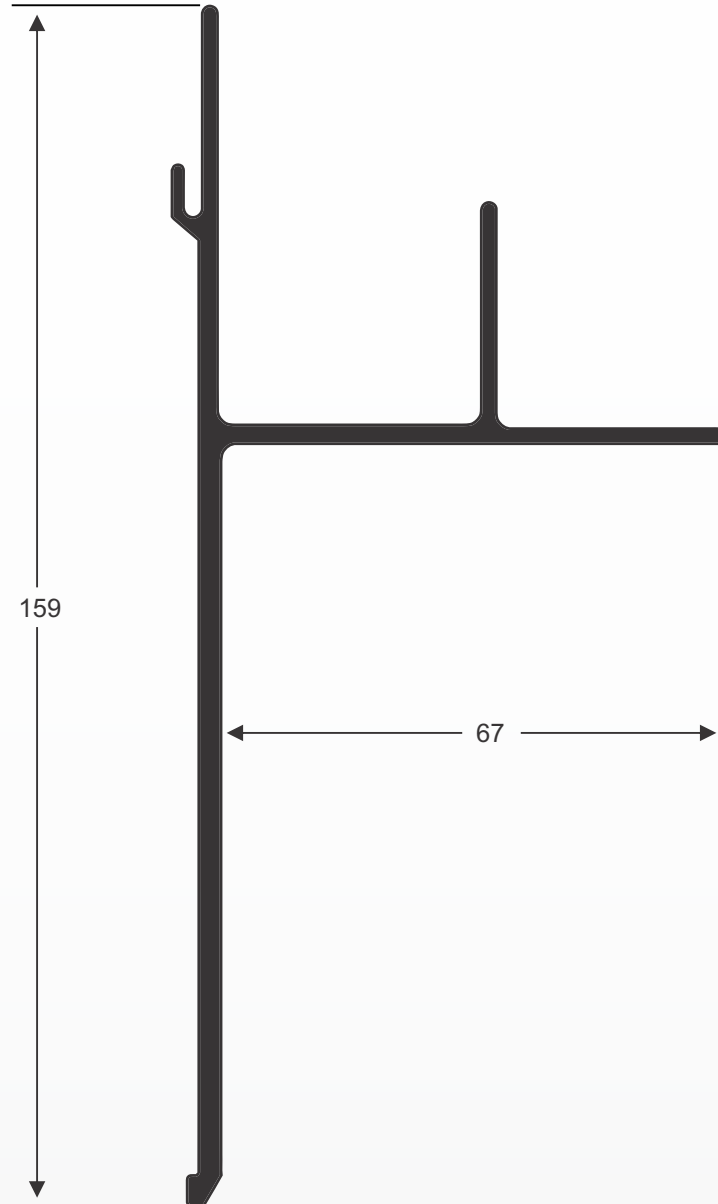

STL-1173

Merc. -----

Peso 1,697 kg/m

Descr. -----

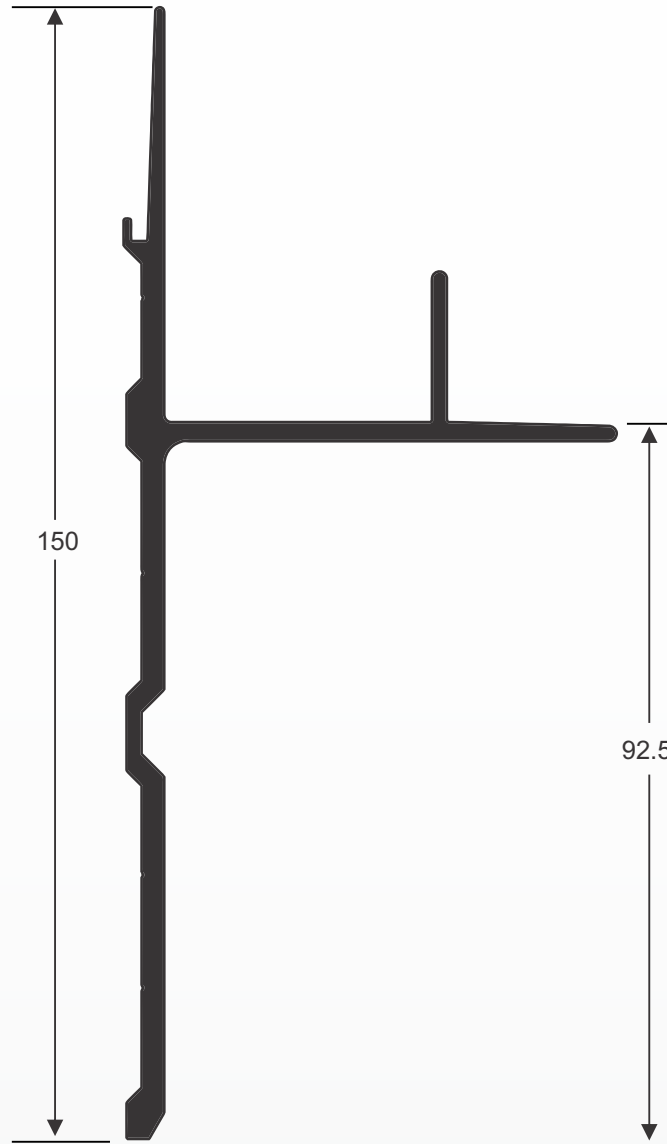

STL-1182

Merc. -----

Peso 1,463 kg/m

Descr. -----

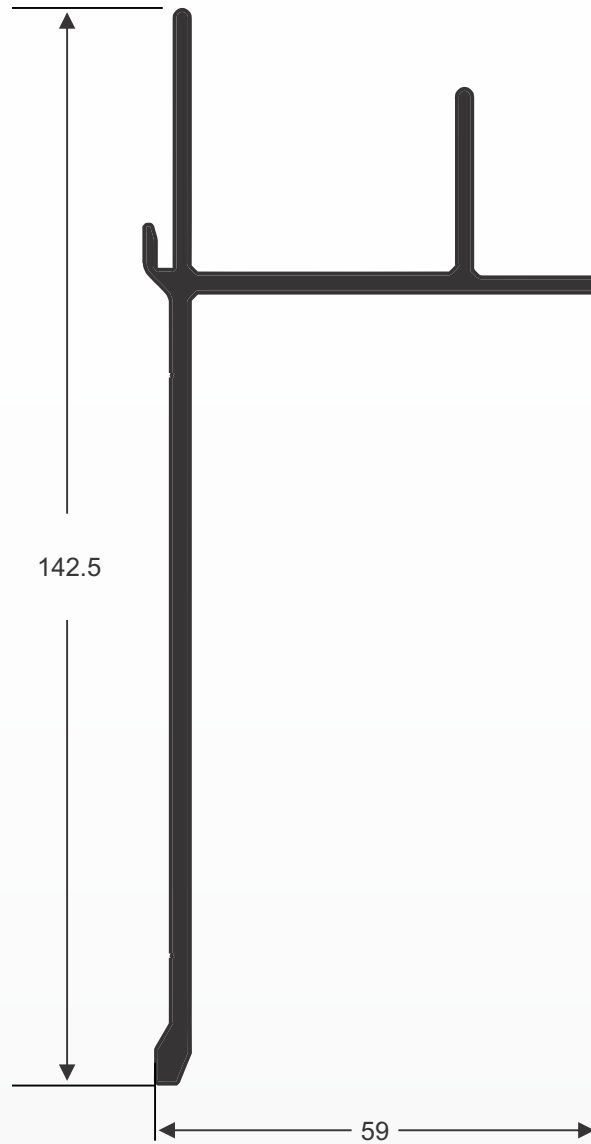

STL-1184

Merc. -----

Peso 1,261 kg/m

Descr. -----

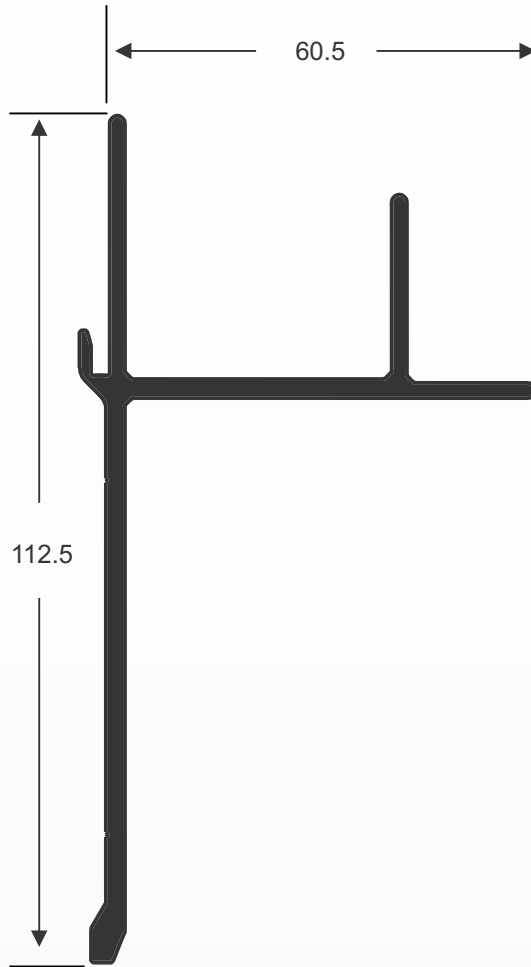

STL-1324

Merc. -----

Peso 1,965 kg/m

Descr. -----

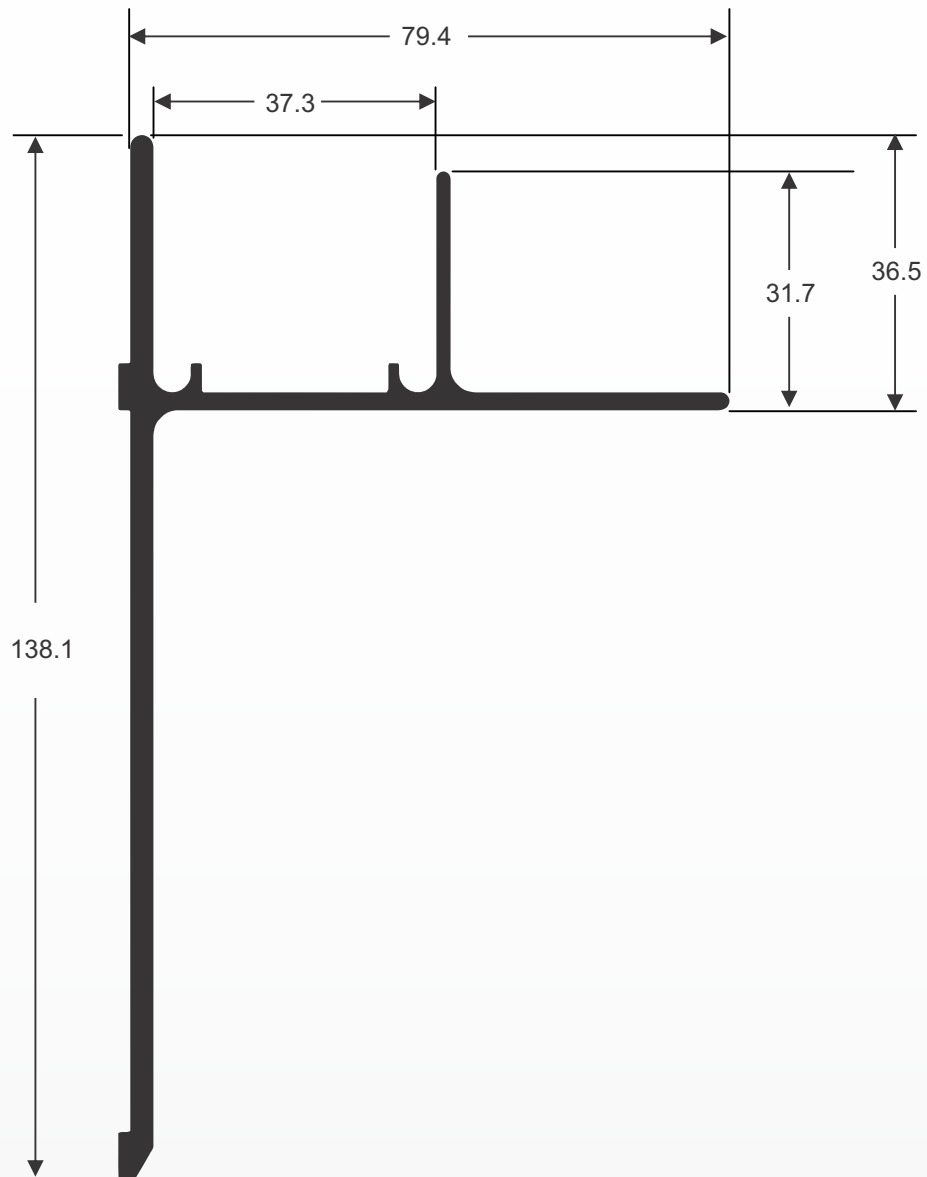

STL-1325

Merc. -----

Peso 1,734 kg/m

Descr. -----

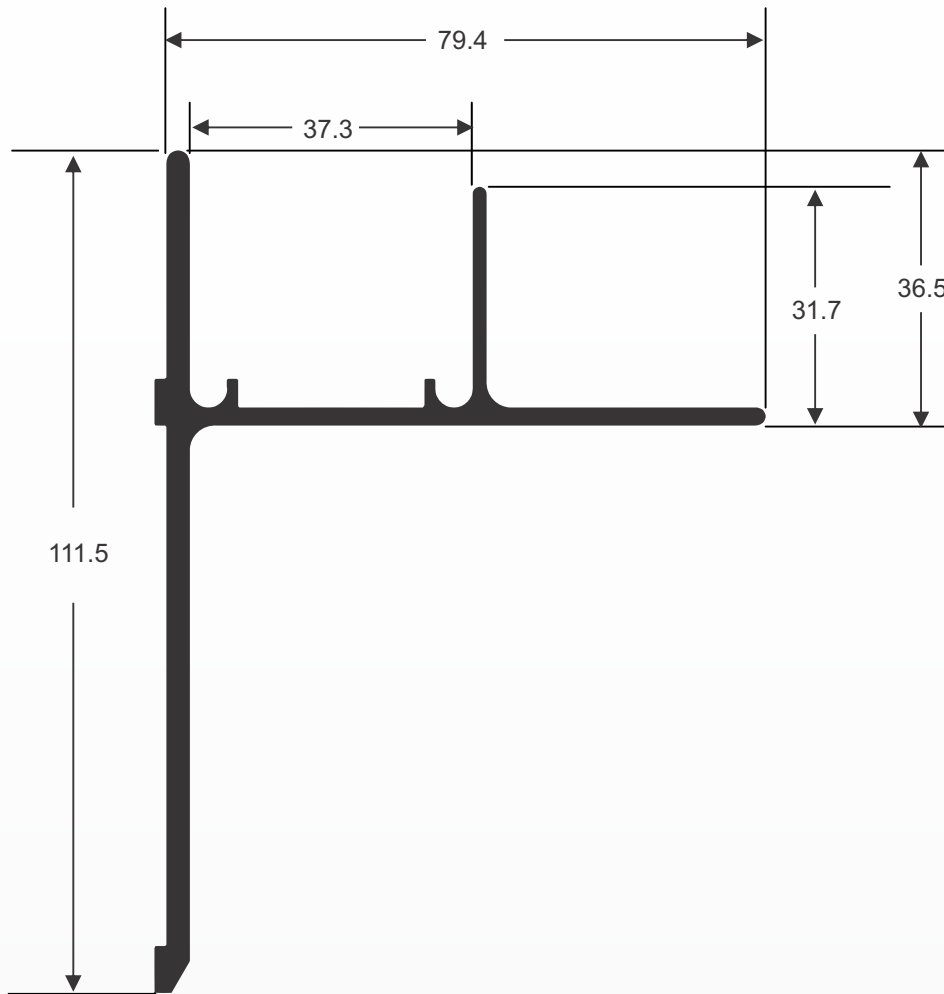

STL-0974

Merc. -----

Peso 1,723 kg/m

Descr. -----

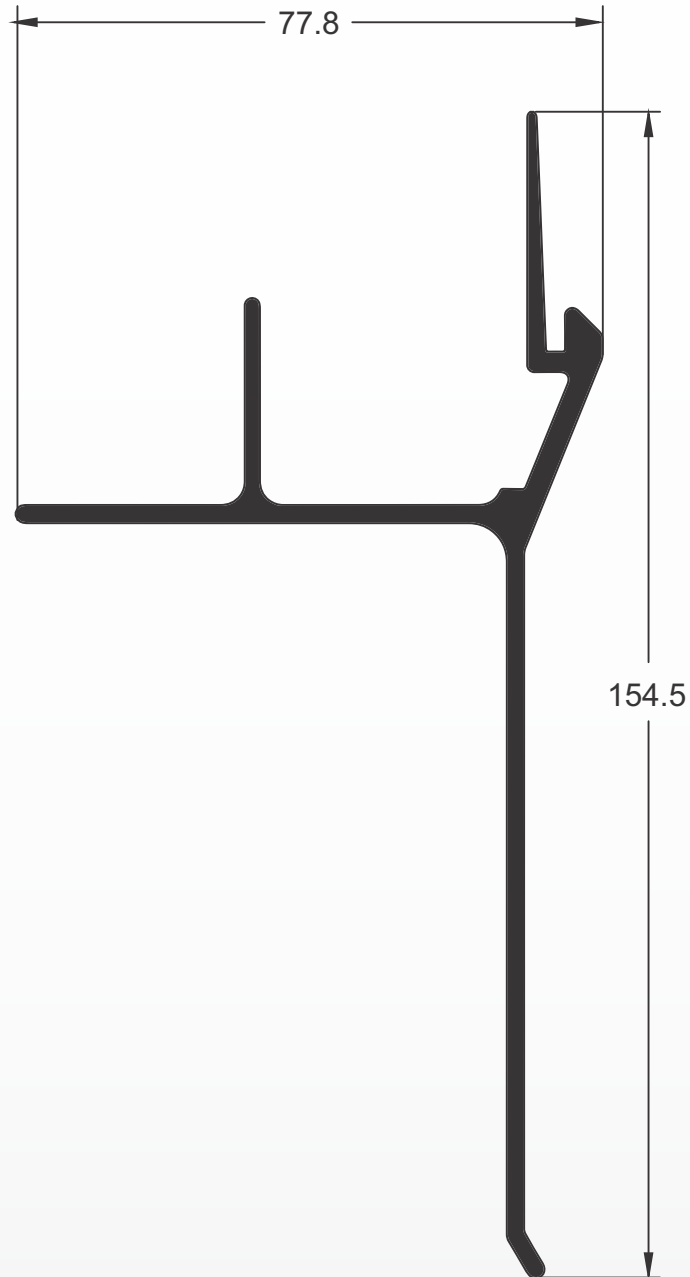

STL-0996

Merc. -----

Peso 1,781 kg/m

Descr. -----

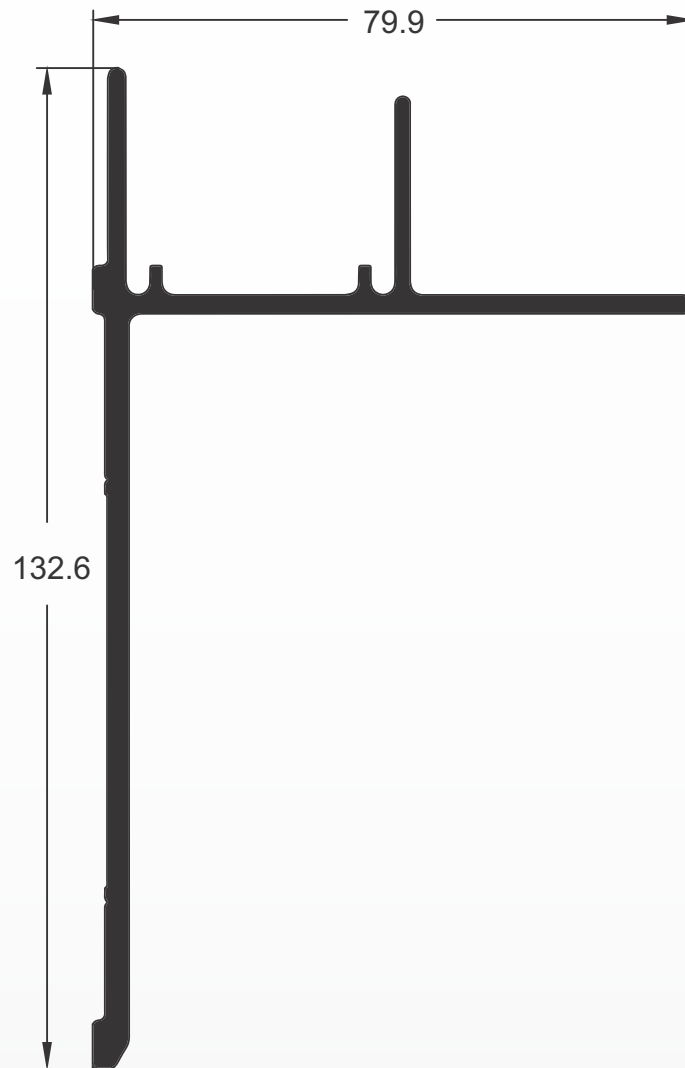

STL-0995

Merc. -----

Peso 1,300 kg/m

Descr. -----

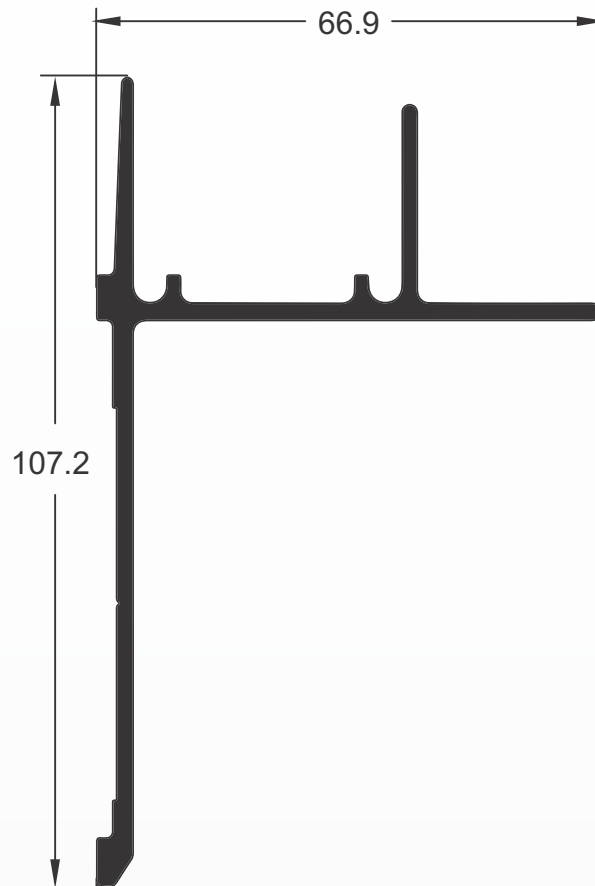

STL-1043

Merc. -----

Peso 1,348 kg/m

Descr. -----

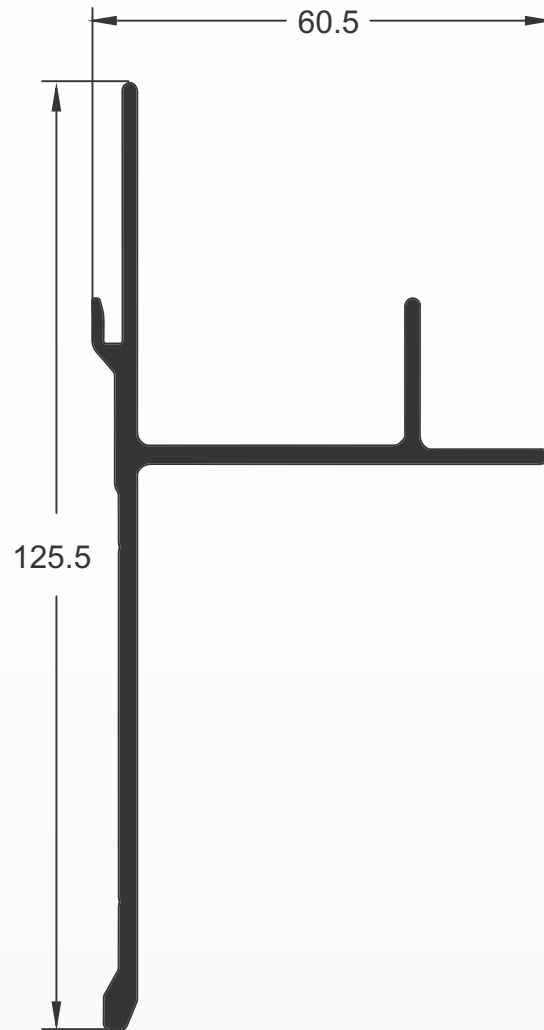

STL-1317

Merc. -----

Peso 2,463 kg/m

Descr. -----

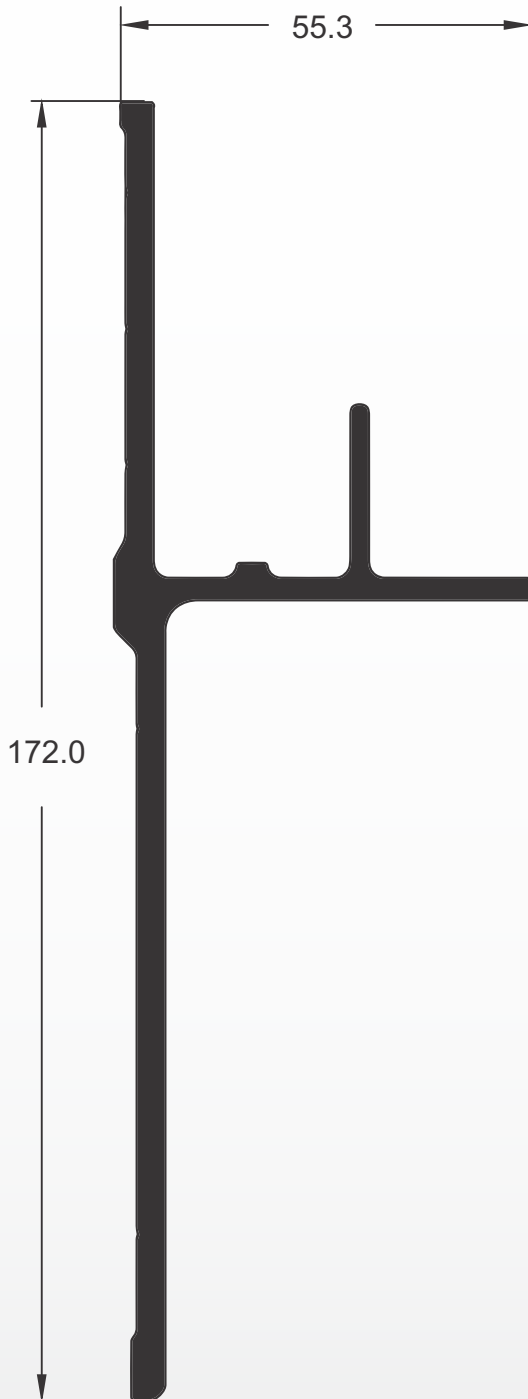

STL-1318

Merc. -----

Peso 1,551 kg/m

Descr. -----

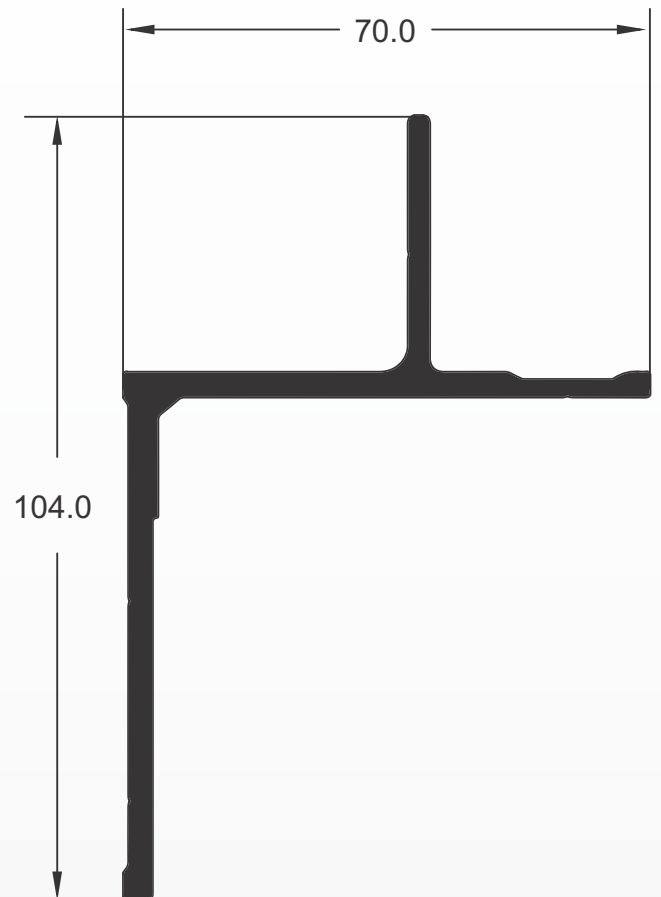

STL-1327

Merc. -----

Peso 1,373 kg/m

Descr. -----

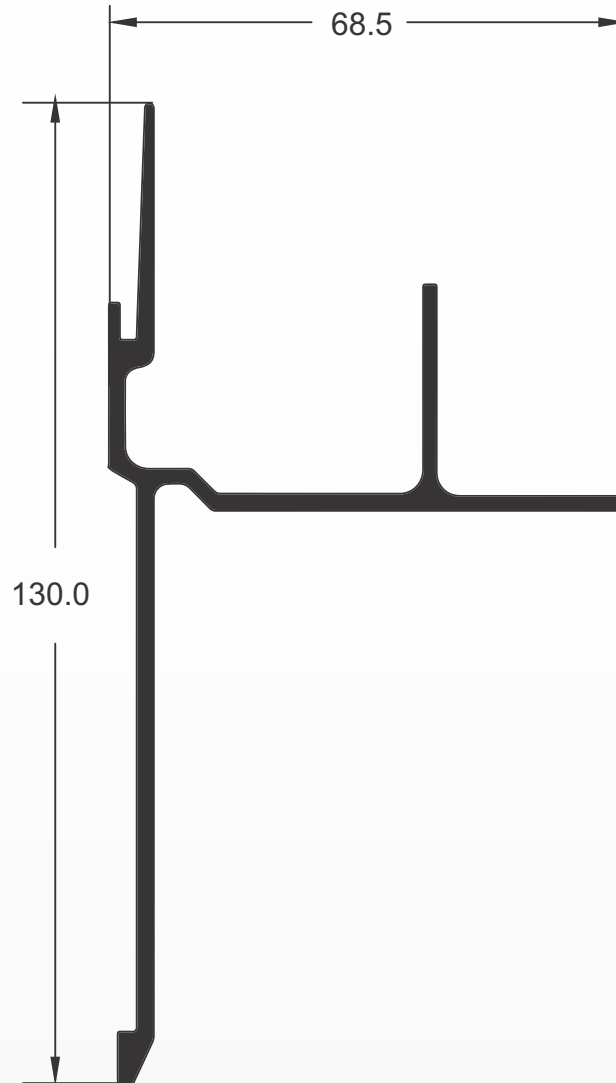

STL-0946

Merc. -----

Peso 0,355 kg/m

Descr. -----

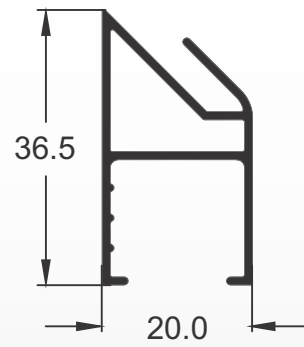

STL-0660

Merc. -----

Peso 1,787 kg/m

Descr. -----

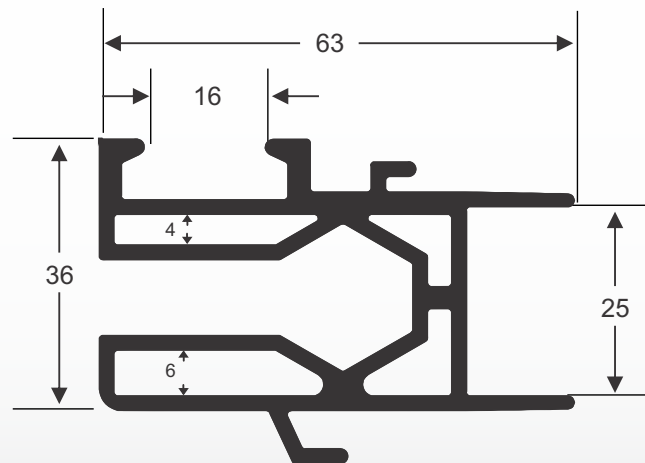

STL-0991

Merc. -----

Peso 0,978 kg/m

Descr. -----

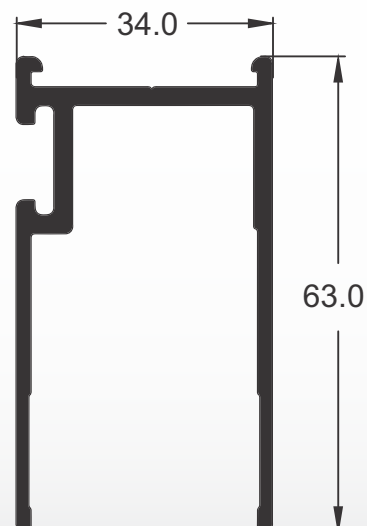

STL-1864

Merc. -----

Peso 1,353 kg/m

Descr. -----

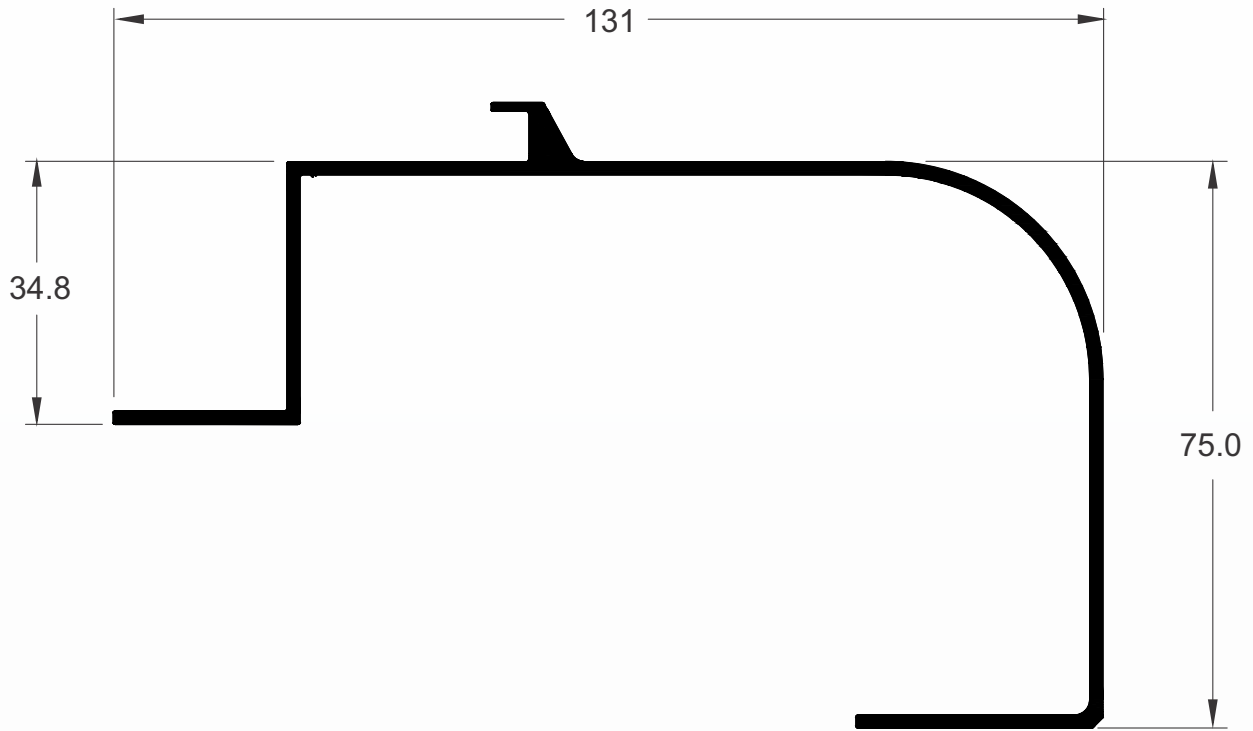



STL
ALUMÍNIO



stlaluminio.com.br



Av. Industrial, 1500 - Distrito Industrial - CEP 08586-150
Itaquaquecetuba - SP - Tel.: 55+ 11 4233-9012